



**International Journal of Environment and Climate Change**

**Volume 13, Issue 9, Page 1355-1362, 2023; Article no.IJECC.102922**

**ISSN: 2581-8627**

*(Past name: British Journal of Environment & Climate Change, Past ISSN: 2231-4784)*

# **A Finite-Element Method for Enhancement Issues of Frame of Battery Operated Ridge Planter with Drip Line Installer**

**Kunal Bhelave<sup>a++\*</sup>, Atul Kumar Shrivastava<sup>a#</sup>  
and Balveer Singh Meena<sup>a++</sup>**

<sup>a</sup> *Department of Farm Machinery and Power Engineering, College of Agricultural Engineering, Jawaharlal Nehru Krishi Vishwa Vidhyalaya, Jabalpur (M.P.), India.*

**Authors' contributions**

*This work was carried out in collaboration among all authors. All authors read and approved the final manuscript.*

**Article Information**

DOI: 10.9734/IJECC/2023/v13i92364

**Open Peer Review History:**

This journal follows the Advanced Open Peer Review policy. Identity of the Reviewers, Editor(s) and additional Reviewers, peer review comments, different versions of the manuscript, comments of the editors, etc are available here: <https://www.sdiarticle5.com/review-history/102922>

**Original Research Article**

**Received: 04/05/2023**

**Accepted: 07/07/2023**

**Published: 18/07/2023**

## **ABSTRACT**

Using distinct partial differential equations, complicated structures breaks down into small elements using the computational approach known as finite element analysis (FEA). Engineers in agriculture can investigate the behavior of numerous input products using numerical simulation based on the FEA technique in order to enhance the design of any machine without constructing a prototype. The current study employed the FEA technique to develop and simulate the frame of a battery-operated ridge planter with a drip line installer. A static structural test was performed through using the FEA technique in the ANSYS version 15.0 workbench software, and a 3D-CAD model of the frame of a

<sup>++</sup> *Ph.D Scholer;*

<sup>#</sup> *Dean and Head;*

<sup>\*</sup>*Corresponding author: E-mail: kunaljnkv@gmail.com;*

*Int. J. Environ. Clim. Change, vol. 13, no. 9, pp. 1355-1362, 2023*

battery-operated ridge planter with drip line installer was made using the Solid Works software. To determine the force necessary in the universal testing machine and the applied forces, respectively, on the frame, a specific fixture has been generated.

Total deformation was measured at 23313 mm, and the simulation revealed that the maximum shear stress, equivalent stress, normal stress, stress intensity, and strain energy were, respectively, 8.40 MPa, 16.68 MPa, 16.4 MPa, 16.8 MPa, and 3.55 MPa at 1817.5 N of total load acting on the frame.

The stress values are within the material's yield strength, it was also observed. The FEA methodology was discovered to be a way for creating and simulating the frame of a battery-operated ridge planter with drip line installer that is very effective and scientific.

*Keywords: ANSYS; battery; sowing; drip-line; deformation; stress; intensity etc.*

## 1. INTRODUCTION

Nearly 60% of the country overall horticultural production is comprised of vegetables. India is currently the world's second-largest vegetable producer. Vegetable farming covered 10.26 million hectares in India in 2017–18, producing 184.40 million tones and producing 17.97 MT/ha, respectively. The top five states that produce the most vegetables are Uttar Pradesh, West Bengal, Madhya Pradesh, Bihar, and Maharashtra. The production area in Madhya Pradesh was 0.92 million hectares, with a production of 18.1 million tones, and the productivity was 19.57 MT/ha.

The traditional technique of planting is tedious, time-consuming, fatigue, and backache due to the longer duration required for maintaining the metering of seeds if overfill and bunching are to be avoided [1]. The area of the field that can be planted is constrained by manual techniques' poor seed placing, low efficiency, late planting, as well as substantial stiffness issues for farmers. One of the most important aspects that may be achieved effectively through the proper application of agricultural machinery is timeliness of operation.

Water is an essential factor in agricultural production. In arid and semi- arid regions of India, water availability is becoming a major challenge for farm production [2]. Therefore, it is important to manage the water resources that are already available wisely by adopting irrigation technology that enhances vegetable production both per unit area and per unit of water used. Drip irrigation was subsequently used to increase crop productivity and water use efficiency. Using the drip irrigation method, water is delivered to plant roots at a controlled rate.

Precision planting was defined as the putting of a single seed and uniform seedling within soil at

the specified plant spacing. A precision planter is a sowing device mounted with single seed metering devices. Horizontal plate planters with cells on the periphery had been the first precision planter [3]. Despite that the inclined and vertical plate seed metering become extensively used, however caused problems such as high seed damage and missing and multiple seed drops. To overcome this problem and reduced these losses, and horizontal plate become developed and used. To attain correct seed spacing, numerous parameters affecting placement ought to be optimized for a given seed size, along with the shape of the seed at the disc for simulation of the seed and the speed of the disc, to adjust seed spacing. Seed spacing is defined as the proper seed to seed distance through planter [4,5], and seed rate is actual seed dropped on unit area [6] are most performances parameters.

High labour demands in operation in a crop production system cannot or have not been mechanized. In order to obtain an adequate return, manpower peaks in the bund-making, sowing, and drip line-installing processes must be mechanized. In order to support all machine components, a structure is created for bund construction, sowing, and installing drip lines. Frames are strong, affordable, and strengthful.

"Finite element analysis, also known as finite element method, is a numerical technique that approximates solutions to boundary value problems involving algebraic equations by breaking complex structures into a number of small elements" [7]. "Although the precise beginnings of FEA are undetermined it is becoming an increasingly widely as a result of advancements in computer technology. This method relies on the concepts of constructing and solving hypothetical equations for the problem, identifying the problem's domain, and

calculating the relevant variables” [8]. Before creating mechanical prototypes, engineers or developers can utilize FEA to examine the behavior of different input materials, helping with the production process as well as monitoring and spotting any usability issues or material failures. Software like AutoCAD, CREO, ANSYS, SolidWorks, CATIA, and others are available on the market to design and simulate any mechanical part of the body. These serve a variety of objectives and are employed by particular fields for specific objectives [9]. For doing finite element analysis and resulting in numerical solutions to a variety of mechanical problems, ANSYS is the most versatile and often used programme among engineers. Static/dynamic, structural analysis, transfer of heat, fluid, acoustic, and electromagnetic issues are some of these issues [9].

Despite being widely utilized in mechanical design, the finite element method is still in its infancy when it comes to developing agricultural equipment. Additionally, a battery-operated ridge planter with drip line installer was examined in the context of an evaluation of research on FEM. In order to assess if the design was appropriate for development, this study set out to build a 3D model of the frame of a battery-operated ridge

planter with drip line installer and simulate it using the FEA approach.

## 2. MATERIALS AND METHODS

Creo Parametric (version 7.0) and ANSYS workbench (version 15.0) software were used to design and simulate the frame of the battery-operated ridge planter with drip line installer, which was then manufactured at JNKVV, Jabalpur. Mild steel (MS) was used in the fabrication of these components because of its many design-friendly physical and mechanical characteristics, as well as because it is affordable and widely available.

### 2.1 Main Frame

The pipe frame's basic structure was made of 50 mm CI pipe for mounting various components of the seed sowing, bund making and drip line installing such as metering mechanism, three ridger, drip line installer, and so on. Two pairs of CI pipes, each with a length of 6000 mm, a width of 50 mm, and a thickness of 3 mm, were cut and welded repeatedly to shape the pipe frame, allowing the developed battery operated ridge planter with drip line installer mechanism to be installed within it, as shown in Fig. 1.

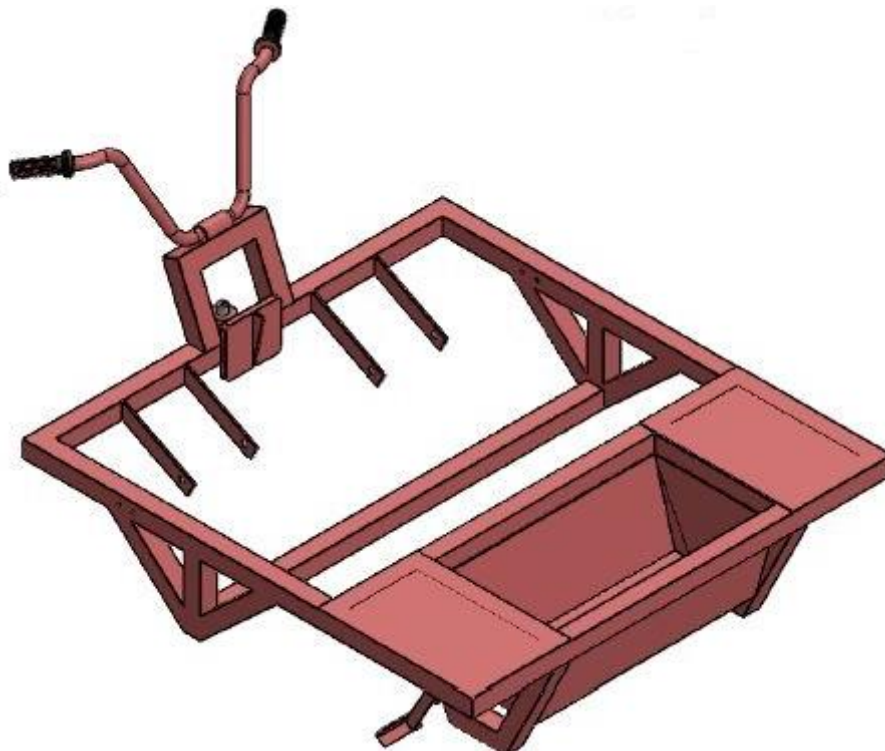

Fig. 1. Solid work design of frame

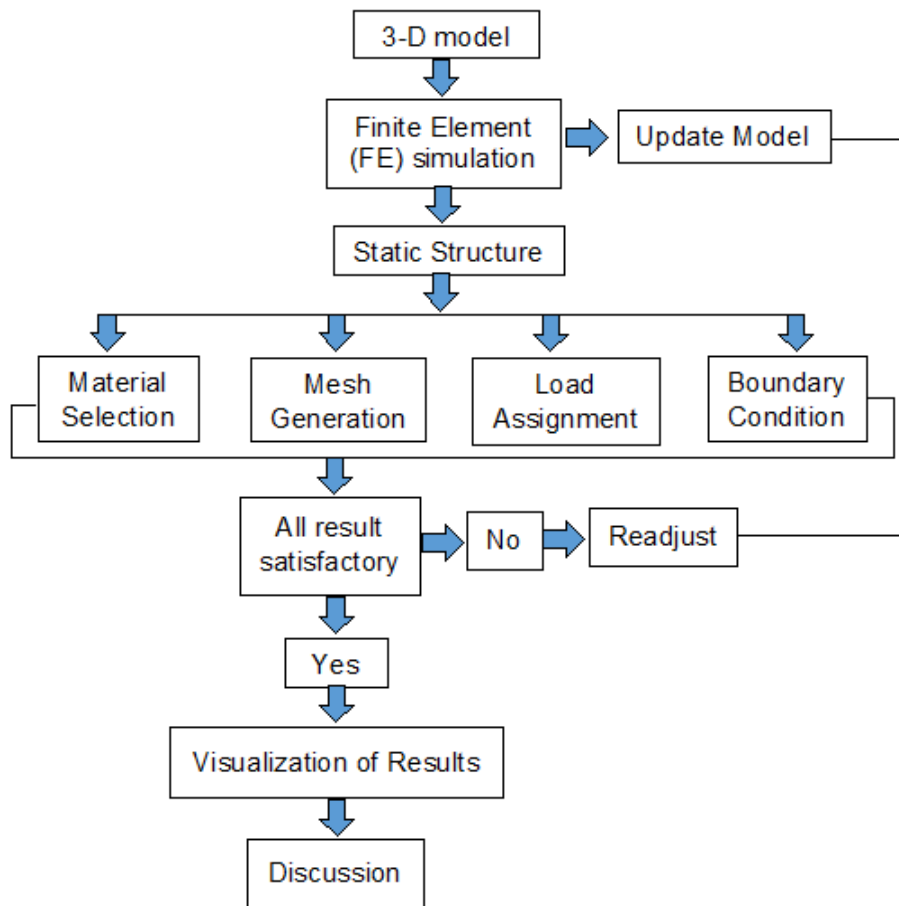

Fig. 2. Flow diagram of an ANSYS software process

Table 1. Physical properties of the material

S.No	MS STEEL	
	Physical properties	Details
1	Modulus of elasticity	208
2	Density, kg/m <sup>3</sup>	7800
3	Tensile strength, MPa	350
4	Yield strength, MPa	175
5	Poisson's ratio	0.29

## 2.2 Process of ANSYS Analysis on the Developed Frame

Table 1 displays the physical parameters of the materials, and Fig. 2 represents the flow diagram of an ANSYS software programme. The following steps made up the entire analysis: -

- 1 There are only three processes used in the ANSYS programme for the analysis of any part: pre-procedure, procedure, and post-procedure.
- 2 Initially, applying the solid works software to create the 2D and 3D CAD models.

- 3 The force, boundary condition, and fix point are taken into account in the pre-procedure previous to the meshing process starts. We are aware of the total number of elements and nodes following the meshing process.
- 4 The displacement, conducted stress, and strain forces in the frame's structure are then determined using the static analysis.
- 5 All parameters are investigated to see if they stumble within the permissible limits for the materials that were selected.
- 6 The most probable outcome is then recorded.

## 2.3 Battery-Operated Ridge Planter with Drip Line Installer Frame Finite Element Analysis

The main user interface shows wide range of analytical system after launching ANSYS Workbench. Since, main objective of this study was to examine the structural stress analysis of the frame of tractor operated single row maize

cobs picker, therefore Static Structural Analysis (SSA) tool was selected. The material used for construction of frame is MS and properties of MS not available in the existing library. Therefore, it is essential to create a new material library with isotropic elasticity and density options. The properties of MS used in the analysis are shown in Table 1. The next important step of FEM is to define the geometry, for this previously developed CAD model was imported through design modeler which is a parametric geometry modeler. The main advantage of design modeler is easy manipulation of existing geometry. After that meshing was done to perform the accurate simulation using FEA. A mesh was created using the elements which contain the various nodes (coordinate locations in space that can vary by element type) that represent the shape of the geometry. The default meshing option was opted. The boundary conditions of the model need to be carefully applied on to model in analysis setting. Frame are supported by wheel and the load apply on the frame is approximately 1817.5 N. After applying the boundary conditions, static structural simulation was carried for selected parameters like total deformation, maximum shear stress, equivalent stress, normal stress, stress intensity and strain energy were found and shown in Figs. 3, 4, 5, 6, 7 and 8.

### 3. RESULTS AND DISCUSSION

#### 3.1 Total Deformation

Total deformation of the model indicates the portion where maximum force and bends occur. It also includes that how much reaction force required to bend a material. Furthermore, it is

used to obtain the displacement from applied stress. Summation of square of all the directional i.e., x, y and z gives the total deformation of the model. The color red and blue indicates maximum 23313 mm and minimum 12763 mm deformation (Fig. 3). It was evident from the results that maximum deformation was observed in center where the leaves undergo beating and scrapping. The analysis showed that maximum deformation is at front and back side frame model. The frame model made of mild steel has less deformation than the yield point of the material [10].

#### 3.2 Maximum Shear Stress

The breakdown of material depends on the maximum shear stress of the product. The color chart of the model indicates maximum and minimum shear stress. The maximum shear stress was found to be 8.40 MPa while minimum as  $1.20 \times 10^{-6}$  MPa (Fig. 4). The maximum shear stress of model is lower than its shear stress (200-300 MPa) [10] which shows that deformation does not cause much failure on the frame (Fig. 4).

#### 3.3 Equivalent Stress

Equivalent stress is computed to estimate yield failure criteria in ductile materials as shown in Fig 5. The maximum equivalent stress was found to be 16.68 MPa whereas the minimum was found as  $2.10 \times 10^{-6}$  Mpa. Jakasania et al [11] conducted the similar study and suggested that, in designing model, working stress should take the lower than the maximum or ultimate stress at which failure of the material take place.

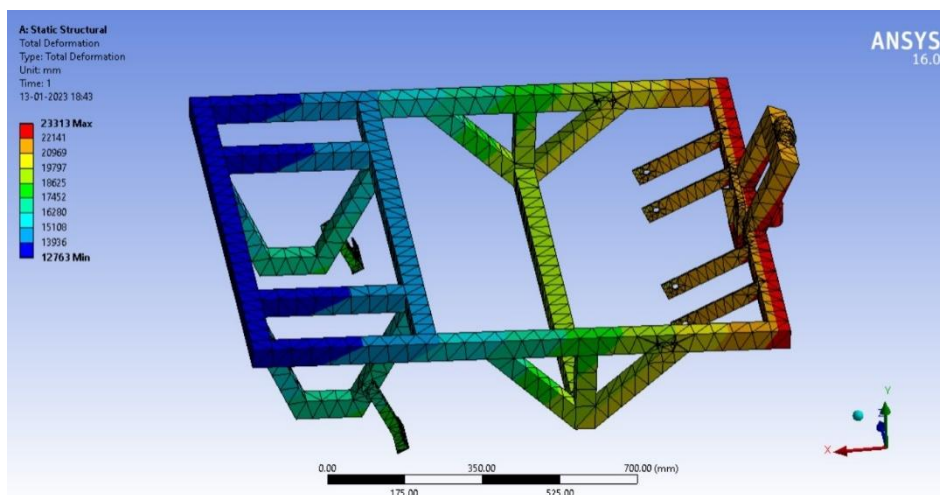

Fig. 3. Total deformation



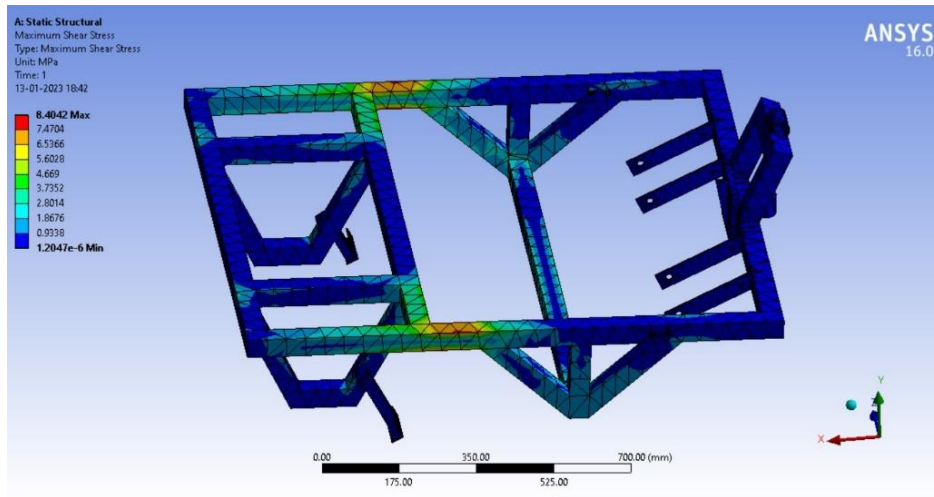

Fig. 4. Maximum shear stress

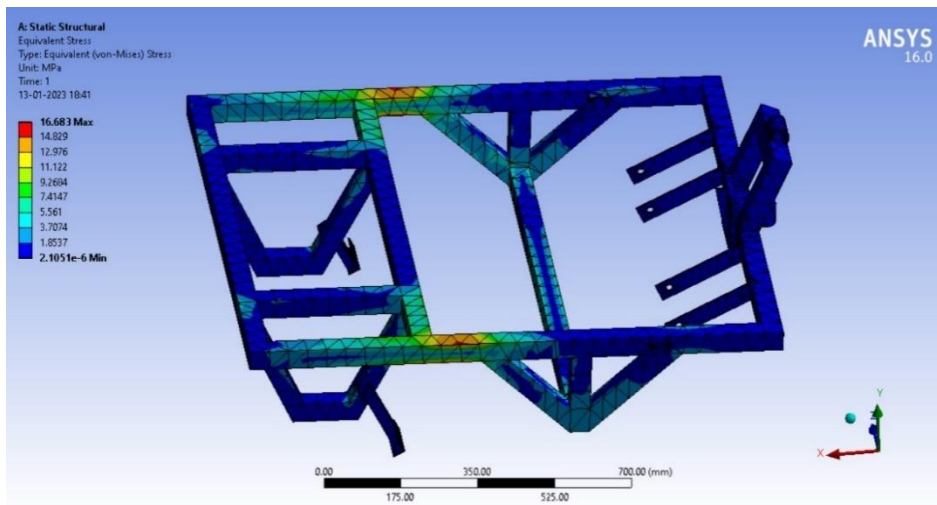

Fig. 5 Equivalent stress

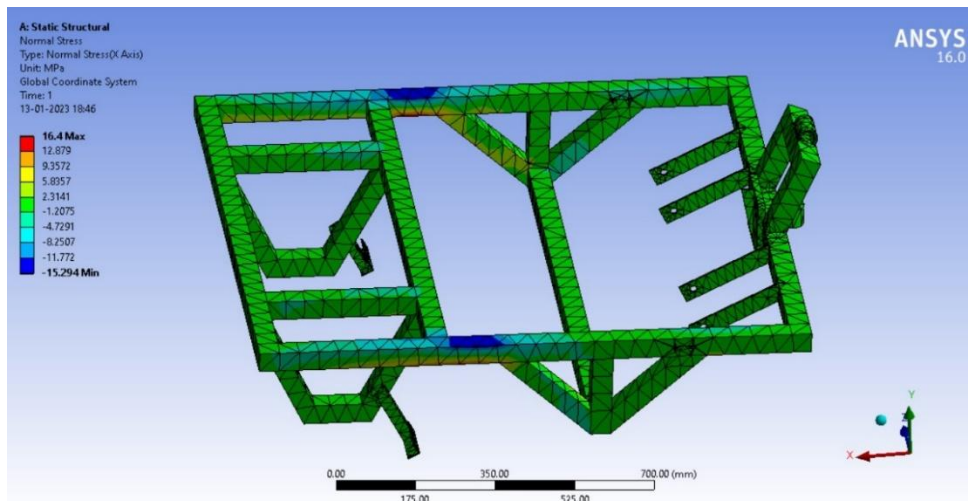

Fig. 6. Normal stress

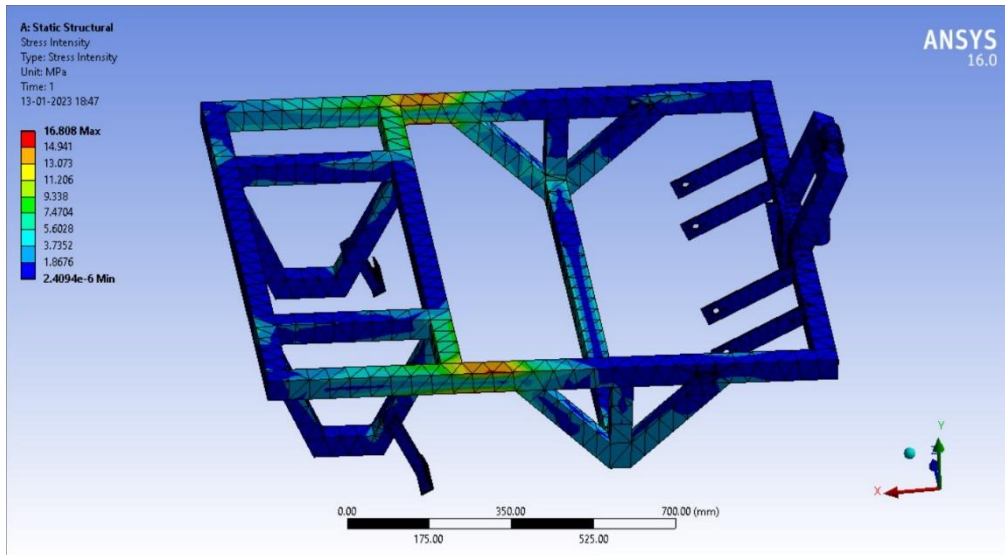

Fig. 7. Stress intensity

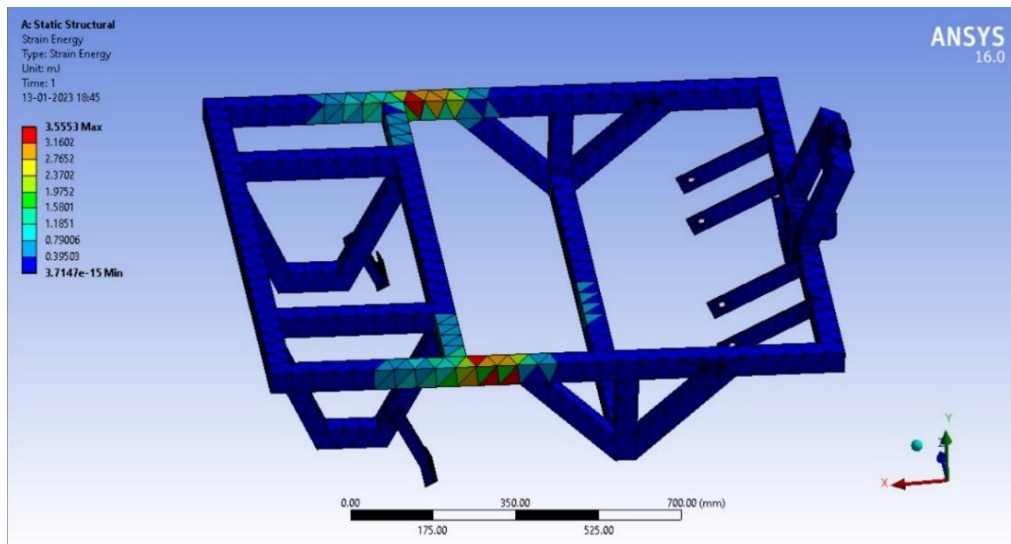

Fig. 8. Strain energy

### 3.4 Normal Stress

Normal Stress of the frame were stress on a surface that represents the cross-section of a part in tension. The maximum normal stress was found to be 16.40 MPa whereas minimum normal stress as -15.29 MPa shown in Fig. 6.

### 3.5 Stress Intensity

Stress intensity on frame was compared to a critical value and evaluate whether a component or structure is prone to fracture [12]. The maximum stress intensity found to be 16.80 MJ and the minimum was  $2.40e^{-6}$  mJ (Fig. 7).

### 3.6 Strain Energy

Strain energy is the energy stored in a body due to deformation. Strain energy in the model the maximum strain energy was found to be 3.55mJ and the minimum was 3.71e-15 shown in Fig. 8.

## 4. CONCLUSION

To design and simulate the frame of a battery-operated ridge planter with drip line installer, a 3D CAD model was made in the Solid Works design programme, and a static structural analysis was carried out in the ANSYS version

15.0 workbench programme. In order to calculate the force required to install drip lines, make bunds, and plant seeds in the Universal Testing Machine, a specific fixture has been created. Maximum deformation was calculated to be 23313 mm at 1817.5 N total force, including the weight of all parts, while maximum shear stress, equivalent stress, normal stress, stress intensity, and strain energy were predicted to be 8.40 MPa, 16.18 MPa, 16.4 MPa, and 16.80 MPa a, d 3.55 MJ, respectively. It was discovered that the stresses' values matched within the material's yield strength. As a result, it was found that the FEA technique is a very effective and scientific method for designing the frame of a battery-operated ridge planter with drip line installer. Based on this discovery, a prototype of the frame of a battery-operated ridge planter with drip line installer can be created.

### COMPETING INTERESTS

Authors have declared that no competing interests exist.

### REFERENCES

1. Bamgboye AI, Mofolasayo AS. Performance evaluation of a two-row okra planter. International Commission of Agricultural Engineering (CIGR, Commission Internationale du Genie Rural) E-Journal 2006;8(1):1-10.
2. Anonymous. To combat scarcity, increase water use efficiency in agriculture. World Watch Institute. 2013:1-3.
3. Datta RK. Development of some seeders with particular reference to pneumatic seed drills. The Harvester, Indian Institute of Technology, Kharagpur India 1974; 16(1):26-29.
4. Korayem A, Younis S, Hemada A. A study of some factors affecting the accuracy of corn planter. Alexandria Journal of Agricultural Sciences 1986;32(2):27-46.
5. Kachman SD, Smith JA. Alternative measures of accuracy in plant spacing for planters using single seed metering. American Society of Agricultural Engineering. 1995;38(2):379-387.
6. Heege HJ. Seeding methods performance for cereals, rape and beans. Transactions of the American Society of Agricultural Engineering (ASAE).1993;36(1):653-661.
7. Zienkiewicz OC, Taylor RL, Zhu JZ. The finite element method: Its basis and fundamentals; 2013. Hardcover ISBN: 9781856176330, EBook ISBN: 9780080951355
8. Velloso NS, Costa ALG, Magalhães RR, Santos FL, Andrade ATD. The finite element method applied to agricultural engineering: A review. Current Agric Res J. 2018;6(3):286-299.
9. Nagesh Kumar T, Prateek Shrivastava, Manisha Jagadale, Shambhu VB, Nayak LK. FEA Technique for design and simulation of sisal decorticator raspador. J Krishi Vigyan. 2022;10(2):173-178.
10. Khurmi RS, Gupta JK. A textbook of machine design. Eurasia publishing house. Ram nagar, New Dehli; 2005.
11. Jakasania RG, Vadher AL, Yadav R. Structural analysis of parabolic type subsoiler using CAD software. Int J of Sci, Environ and Technol. 2016;5(5):3415-3422.
12. Bhelave K, Shrivastava AK, Paliwal RK. Testing of two different powered stationary diesel engines and analysis of changes in performance over usage time. Current Journal of Applied Science and Technology. 2022;41(44):1-7.

© 2023 Bhelave et al.; This is an Open Access article distributed under the terms of the Creative Commons Attribution License (<http://creativecommons.org/licenses/by/4.0>), which permits unrestricted use, distribution, and reproduction in any medium, provided the original work is properly cited.

*Peer-review history:*  
The peer review history for this paper can be accessed here:  
<https://www.sdiarticle5.com/review-history/102922>