



Novel Technique for IRFPA Blind Pixels Detection

Abdulaziz Mohammed Algamdi^{1*} and Ahmad Abbas Ahmad Adas¹

¹King Abdulaziz University, P.O.Box 80204, Jeddah 21589, Saudi Arabia.

Authors' contributions

This work was carried out in collaboration between both authors. Author AMA designed the study, performed the statistical analysis and wrote the first draft of the manuscript. Author AAAA managed and assured the analyses of the study. Author AMA managed the literature searches. Authors AAAA and AMA wrote and developed the technique. Both authors read and approved the final manuscript.

Article Information

DOI: 10.9734/JAMCS/2017/38072

Editor(s):

(1) Metin Basarir, Professor, Department of Mathematics, Sakarya University, Turkey.

Reviewers:

(1) Nilesh Bhaskarrao Bahadure, Solapur University, India.

(2) Manish Mahajan, CGC College of Engineering, India.

(3) Khairul Nizam Tahar, Universiti Teknologi MARA Shah Alam, Malaysia.

Complete Peer review History: <http://www.sciedomains.org/review-history/22195>

Received: 10th November 2017

Accepted: 28th November 2017

Published: 7th December 2017

Original Research Article

Abstract

Infrared focal plane array (IRFPA) is a bi-dimensional infrared detector which is a matrix of micro detectors referred as pixels. Physical pixel failure (blind pixel) is a serious issue in case of utilizing IRFPA as a measuring tool or a surveillance system to monitor hot objects. Scene-based non-uniformity correction (SBNUC) technique for uncooled IRFPA depends on the correction algorithm strength to estimate the correction parameters and to eliminate the need for using the reference-based non-uniformity correction (RBNUC) technique which requires doing a lab calibration instead of self-calibration. SBNUC's have disadvantages of ghosting artifacts which be complex when a new blind pixel appears. This research aims to enhance SBNUC techniques by changing the detection technique blind pixels and apply it in an earlier stage of system operation and to eliminate the need for adding a complex layer of the algorithm over original SBNUC codes for blind pixels detection, only. This research focuses on studying the electrical aspects of IRFPA detector to examine the effect of skimming reference voltage on the global image contrast. This research found out that exciting Vsk by voltage values close to its boundaries could separate blind pixels from the image background which become very exposed and simple to detect and correct. This research proposes a combination of electrical circuit modification, a routine of Vsk voltage excitation along with image acquisition. This research applies Otsu's method as a global thresholding technique to detect blind pixels. Researchers found out that this proposed technique could detect all blind pixels successfully without the need for RBNUC which avoid SBNUC's techniques of lab calibration process to detect the blind pixels.

*Corresponding author: E-mail: abdulaziz.assanani@gmail.com;

Keywords: IRFPA; TPC; blind pixel; SBNUC; IR readout circuit; global thresholding.

1 Introduction

Since replacing the Infrared (IR) scanning technology by the Infrared focal plane array (IRFPA) technology, applications demand got expanded widely. IRFPA is a two-dimensional arrangement of micro infrared detectors (below than 17 μm size, recently) which collect photons on a certain wavelength [1]. Old IR scanning system has consisted of a combined mechanism between one row of micro detectors (a vector of adjacent detectors) and polygon of mirrors which mounted at different angles [2]. In the scanning system, each angle reflects a horizontal stripe (single row) of IR image onto a front vector of IR micro detectors (combined in one chip) to acquire a single raw of picture matrix while polygon moves in a high speed rotating mechanism.

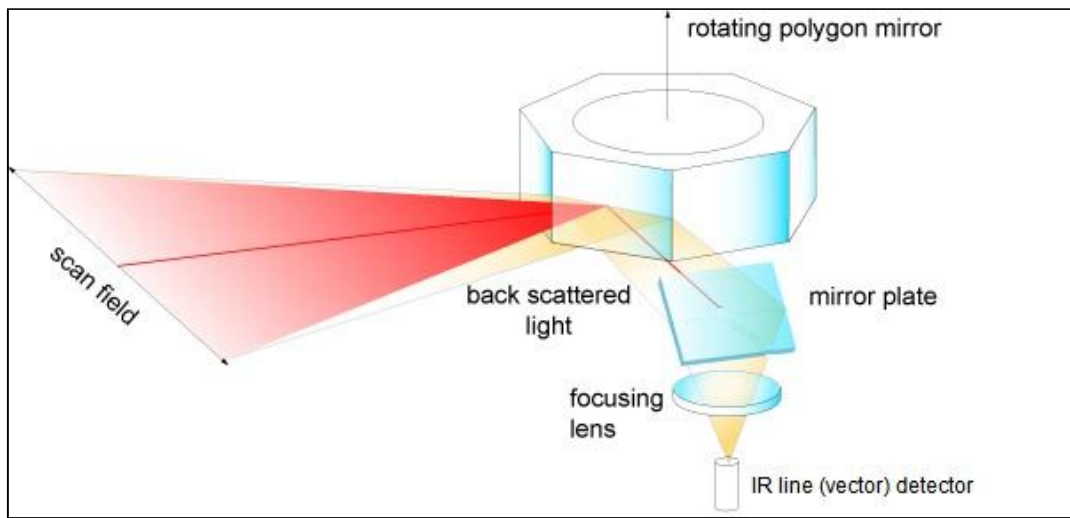

Fig. 1. Traditional optical scanning mechanism

Fig. 1 illustrates that scanning system design was narrowing the chance for a small, lightweight, and lower power system due to the huge mechanical polygon design compared to IR line detector, as in Fig. 1. IRFPA revolution has eliminated the scanning mechanism and extended the demand for applications beyond military and medical purposes [3]. Recently, a trend of very advanced automobile research projects aims to combine IRFPA with other sensing equipment's to increase the safety and reliability of modern cars [4]. In the security field, small and portable IRFPA's are used for purpose of face recognition [5]. The history of IRFPA passed through two major stages and through deep research and developments until they could present an uncooled IRFPA detector that has a small footprint and suitable for commercial purpose applications [6].

Researchers could enhance the feasibility of depending on scene-based non-uniformity correction (SBNUC) algorithms to avoid the need for hardware calibration in labs and to solve the issue of fast IR image drifting which came up as a disadvantage issue in uncooled IRFPA's type [6]. In conventional reference-based non-uniformity correction (RBNUC) which needs a calibration lab, the process should calibrate the response to linearize the image by modeling the output according to the first order slope (gain) and offset coefficients [7]. As in [6], RBNUC priority is to generate two lookup tables for gain and offset that satisfies the following equation:

$$x_{ij} = G_{ij}y_{ij} - O_{ij} \quad (1)$$

Where x_{ij} is the actual radiation, y_{ij} is the pixel response, G_{ij} is the gain value for a pixel and O_{ij} is the offset value for the same pixel.

Also, RBNUC process could be utilized to detect blind pixels. Blind pixels are pixels that have physical failures in their internal structures [8]. RBNUC two-point corrections (TPC) process classifies pixels that their response is unchanging or (slowly change) during the incremented change of reference temperature. These classified pixels shall be shortlisted in a blind pixels lookup table for real-time digital processing. Blind pixel referred to an over-responding, under-responding, or frail-responding micro detector. In image processing, it is so clear that blind pixels in IR could be modeled as a salt and pepper noise and can be easily removed by a 3x3 median filter. Many SBNUC's depend on lookup tables for gains and blind pixels that have been generated by the manufacturer during RBNUC calibration process. Some other SBNUC's do not utilize any of RBNUC's except the blind pixels lookup-table which is not easy to estimate. Of course, lookup-tables are classical technique to solve (correct) the physical failure of the pixels themselves, but it is the easiest and most reliable technique because of many reasons:

- It is a direct and fast way to integrate, retrieve, and utilize with any algorithm. Lookup-tables are very suitable for real time processing while data stream is running.
- Due to rare changes of blind pixels and gains over a short period of time so that there is no need for reserving system resources of implementing complex algorithms for non-frequent use. Of course, the disadvantage is to interrupt the operation and shut down the system for calibration and lookup-table updates.

Due to the growing demand for Uncooled IRFPA and SBNUC techniques which are aiming to avoid the hard-calibration in manufacturer lab, this paper focuses on filling the gap of SBNUC by developing a novel technique to detect the blind pixels during the system initialization stage (when turning the system ON).

2 Background

Although many works of literature call it dead pixel instead of blind pixel [9], the researchers in this paper think that many pixels have a frail-response and they should be classified as blind pixels, too. There are two famous classified situations for blind pixels: the over-responded and under-responded pixels. Moreover, Researchers in this paper include the pixels that have frail-response as a third type of blind pixels and call them bad pixels. Bad pixels still have a weak response when temperature changes which mean that they are active, but they may cost the system extra resources to linearize their responses instead of just consider them as blind pixels without a core change in the system architecture of digital processing. For example, a bad pixel value may need to be multiplied by a gain value that is higher than the maximum possible integer of the fixed- point number representation. In such case, it is more feasible to consider it as a blind pixel and apply a median filter on its position to estimate its value instead of changing the whole digital architecture for minor need.

Blind pixels in IR systems could interrupt any image processing algorithm and be detected as a far hot target (object). Nowadays, IRFPA system is a major part of most military surveillance systems and has an essential mission as an early warning system in aircrafts against thermal missiles which are equipped with thermal seekers instead of radar seekers.

Initially, far objects appear as hot pixels whom their energy are higher than adjacent pixels. According to this observation, military utilizes IRFPA systems as a point target surveillance systems which specify a certain minimal geometrical resolution to classify that hot object under serious monitoring [10].

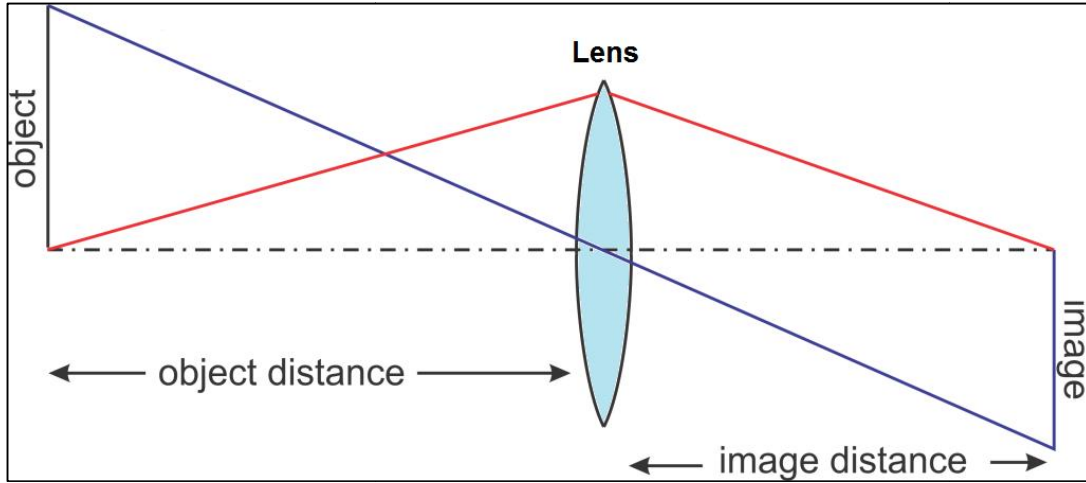

Fig. 2. Instant field of view and geometrical resolution calculation principle

Fig. 2 illustrates the optical aspect of a single image pixel with respect to a far object observation. As an example: to estimate the smallest representation for a far object means to calculate the distance with respect to equivalent pixel size. Suppose that the image in Fig. 2 is a $17\mu\text{m}$ height and object is a 2m height airplane, and the task is to detect and represent this object as a single pixel from 20,000m (20Km) distance; then and from the principle of triangle proportions, system design requires a 17cm focal length for optical lens as follows:

$$\begin{aligned} f &= (H_i/H_o) \times d \\ &= ((17 \times 10^{-6})/2) \times 20000 \\ &= 0.17\text{m} \end{aligned} \quad (2)$$

Where: f is image distance (focal length), H_i is the pixel size, H_o is the far object size, and d is object distance from IRFPA system (see Fig. 2).

Above example demonstrates how critical is when an early warning system has alarmed by the surveillance unit which has an auto-segmentation and objects signature extract algorithms [11]. Detecting a single hot pixel in the scene shall notify that there is a prospective threat from a 20 Km distance.

SBNUC algorithms offer a great solution for uncooled IRFPA drifting issue [1]. SBNUC has two categories: algebraic algorithms which extract global image features (from frame to frame) like neural networks [12], and statistical algorithms which extract local features within the frame itself [3]. Whatever the SBNUC algorithm, its complexity causes some disadvantages that cost more research efforts to solve these side effects [13]. Ghosting artifact is one of the major issues which occurs when an object did not move during the scenario for a long period and then (suddenly) moved. This situation causes a ghost for that object for a while before get (slowly) removed [14].

Blind pixels that appear after a while of system usage are more complex to be solved by an SBNUC algorithm than ghosting artifacts. Most of SBNUC's put up their algorithms on the assumption that there are no new blind pixels that will appear after manufacturer calibration and the system has to retrieve the original blind pixels list (detected by the manufacturer) from a lookup-table and correct the desired blind pixels before feeding the image to SBNUC algorithm as an input for further image processing.

The reality is that new blind pixels will appear over a long period of IRFPA system operation due to an unexpected physical failure. This fact aims few advanced SBNUC algorithms to add a complex layer of

algorithm(s) to detect and update the lookup-table. This new generation of SBNUC algorithms detect new blind pixels among hundreds of non-sequenced frames over a long period of watching inactive pixels while frames are changing. This added layer of complexity will cost the system more resources of processing time and memory (especially in case of implementing the algorithm on an FPGA). The situation becomes worse in case of most of SBNUC algorithms that do not have detection algorithms and assume that what has stored (by the manufacturer) in the lookup-tables are the latest.



Fig. 3. Uncorrected IR image which has some blind pixels

Fig. 3 is an uncorrected image that acquired by uncooled IRFPA system (acquired from a parking zone by the system which researchers used in this research). Some blind pixels can be observed by naked eyes which are so dark dots or so bright as in Fig. 4.

During digital and analog circuit integration, researchers found that some hardwired voltage adjustments affect the global image contrast. This electrical affect aims researchers to study the electrical and operational conditions for IRFPA detector to find if blind pixel responses are influencing, too. Researchers used an IRFPA camera that has a detector from Ulis company (model UL 03 26 2 size 384x288).

Fig. 5 summarizes current methods for blind pixels detection and the proposed technique in this paper.

3 Proposed Technique

Based on our previous project [6], Fig. 6 and Fig. 7 illustrate the whole block diagram that related to the interest of this research and IRFPA experimental system.

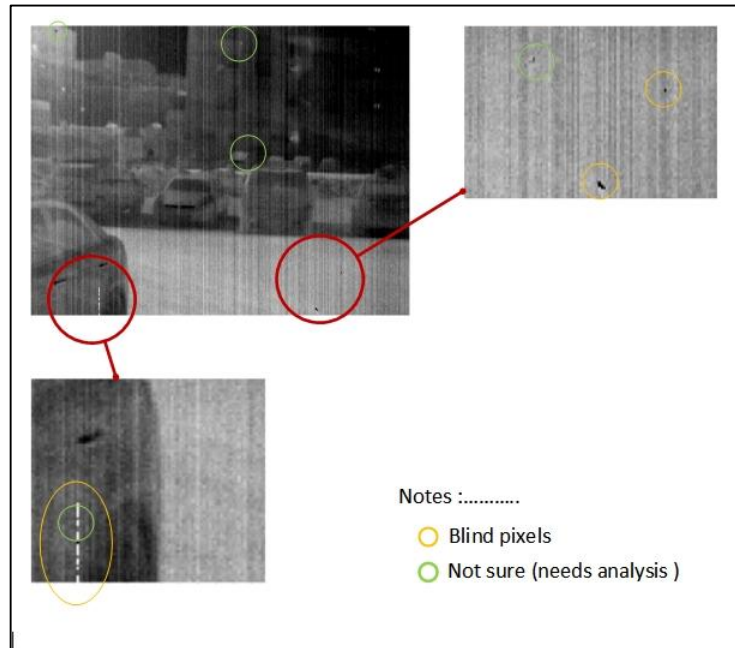

Fig. 4. Fast blind pixels observations

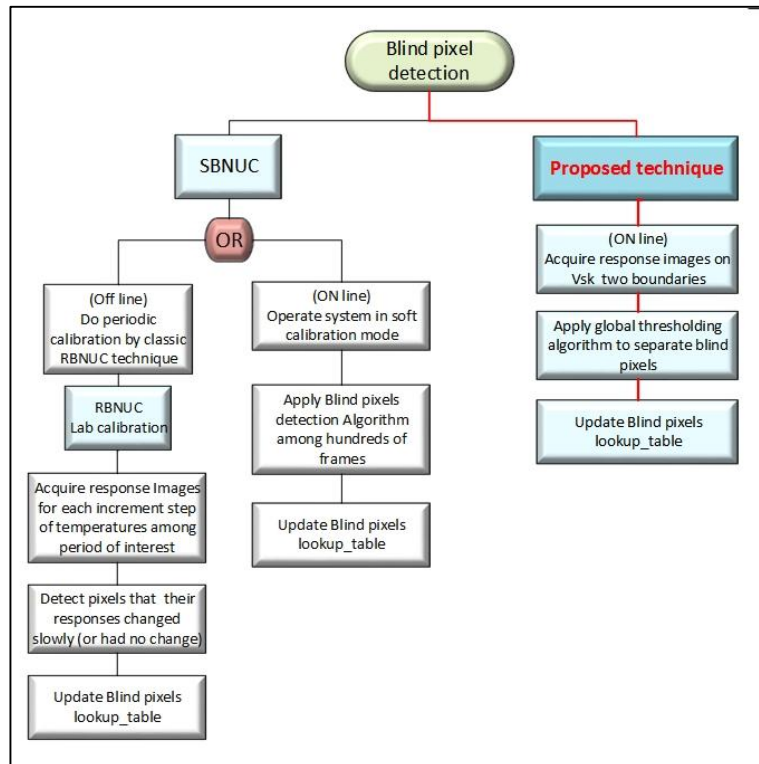

Fig. 5. Blind pixels detection techniques vs. proposed technique

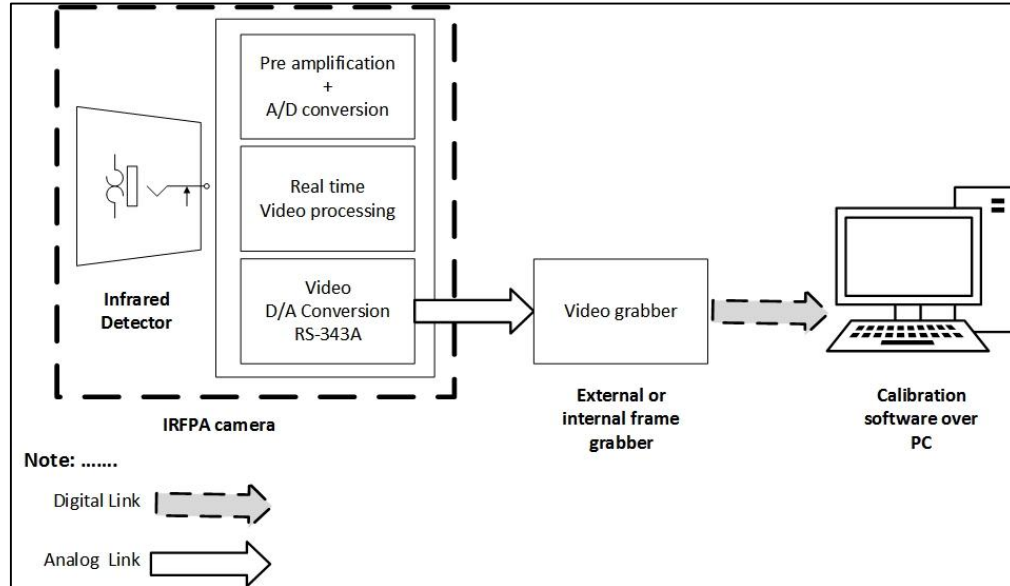

Fig. 6. System basic operation modes

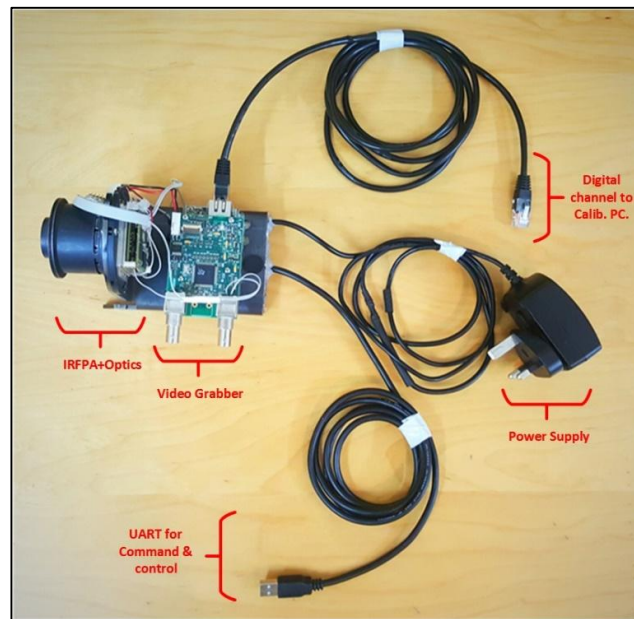

Fig. 7. Experiment setup

Each IRFPA detector must have a readout circuit to inject the desired charges which are required for voltage conversion purposes (sampling). To have a stable readout value and avoid the output voltage from saturation, IRFPA has equipped with a pre-amplification and sampling circuit as in Fig. 8. Usually, manufacturers follow the general model for detector manufacturing process which consists of three major parts: a pixel (a micro detector unit of active bolometer and n-channel enhanced MOSFET), a skimming model, and the sampling circuit.

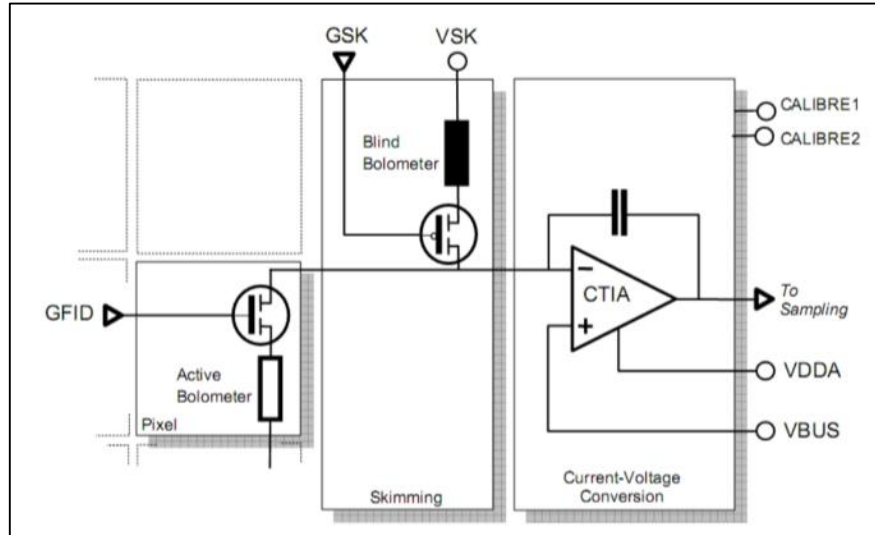

Fig. 8. Ulis (IRFPA detector manufacturer) readout circuit model

The goal of implementing a skimming circuit inside the IRFPA is to avoid the saturation while the blind stage of data transmission (the blind stage differs than the blind pixels which are the main topic for this research) and to support having a smaller pixel size which gives a better dynamic range and signal-to-noise ratio. This research focuses on studying the behavior of skimming on the extreme boundaries of the skimming source voltage (V_{sk}). As in Fig. 8, a p-channel enhanced MOSFET is shunted on the pixel signal line. However, Fig. 8 illustrates the functional model although readout circuits are much more complex than that [15]. For example, there are many designs and patents on how to implement a high-performance skimming module which in some cases have blind bolometers for each IRFPA column instead of individual pixels.

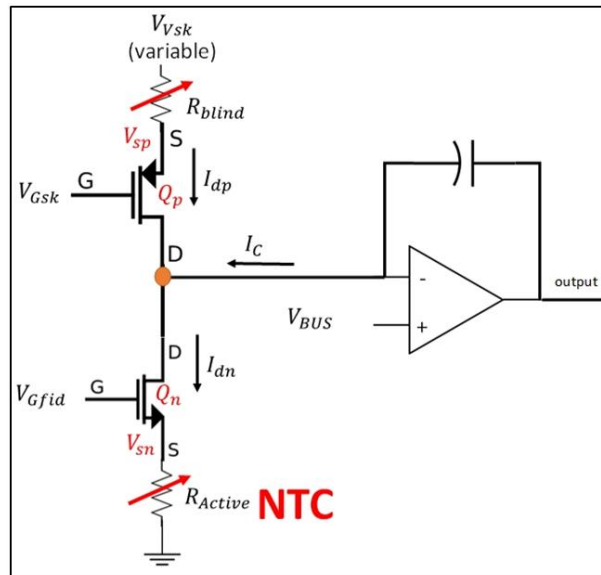

Fig. 9. Readout circuit analysis

According to Fig. 8 and conventional design concepts for readout circuits [15], researchers have drawn the circuit for purpose of analysis as in Fig. 9. Readout circuit designers have supposed that p and n channel MOSFET's operate in triode mode to satisfy the circuit optimal operation requirements, thus:

From KCL:

$$I_c = |I_{dn} - I_{dp}| \quad (3)$$

$$\text{Where } I_{dp} = \frac{V_{vsk} - V_{sp}}{R_{blind}} \quad (4)$$

$$\text{And } I_{dn} = \frac{V_{sn}}{R_{Active}} \quad (5)$$

The most important conclusion from above equation is that I_c represents the absolute difference value for current which charges/discharges the sampling capacitor (buffer). This buffer holds the equivalent representation of the active pixel as a voltage level instead of the desired current consumption. In other words, it acts as a current-to-voltage converter.

Fig. 9 and the equations 3, 4, and 5 show that I_c is a function of:

$$I_c = f \left(\begin{matrix} V_{vsk}, V_{Gfid}, \\ R_{blind}, R_{Active} \end{matrix} \right)$$

With respect to all other parameters, V_{vsk} has an inverse proportional relationship with R_{Active} due to the nature of negative temperature coefficient (NTC) of the active area (pixel sensing region) itself. In other words, the resistance decreases when the source temperature increases. Increasing the voltage of V_{vsk} will increase the absolute difference in the capacitor buffered charges, but due to NTC nature (when the resistivity goes lower it will encourage more current to be drained), it will be discharged by the same amount instead of charging. According to this concept, if the pixel active-area has a defect like a short or open-circuit, then changing the V_{vsk} voltage level to the range boundaries shall emerge blind pixels which are not fluctuating with the same pace.

According to the manufacturer specific test report (STR) which specifies the electrical aspects, it constrains the V_{vsk} voltage level between 2.5V to 5.5V with a recommendation for the optimal 5V voltage level. For experiment purpose and to proof the research concept, researchers insulated the V_{vsk} power feeding line from the main circuit and feed it externally by a very precise power supply. This circuit modification allows to study the effect of V_{vsk} level changing and to find out the best (the maximum and minimum) voltage levels that are the closest to the specification boundaries before letting the detector responses enters the full saturation.

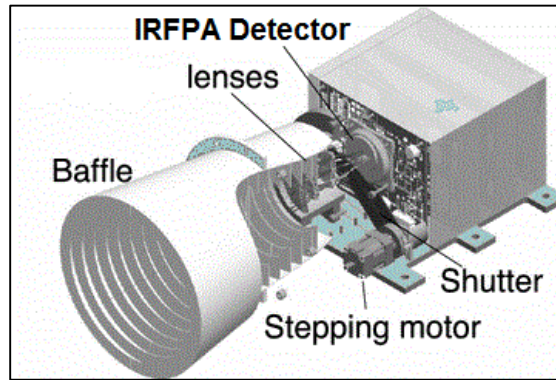

Fig. 10. Mechanical demonstration for IRFPA system

As in Fig. 10, researchers utilize the internal shutter which is located between the lens and detector to close it while doing the experiment. Usually, the shutter is used for a one-point calibration (OPC) process which removes the temporal noise by subtracting its image from any running frame. Shutter is closed while the system initialization and when the level of temporal noise has changed and starts affecting image quality. Researchers modified the initialization routine to include an extra process for blind pixels calibration at this stage of system operation.

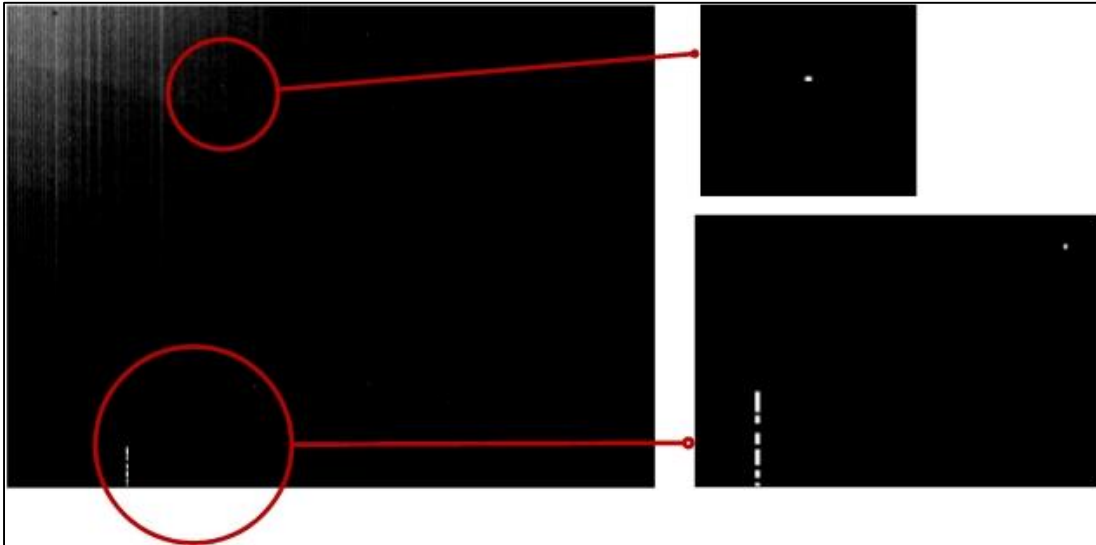

Fig. 11. IRFPA response image when V_{vsk} has increased to 5.276V

Researchers found out that increasing V_{vsk} to 5.276V is the maximum voltage to find out most of the blind (open-circuit) pixels as in Fig. 11; and reducing V_{vsk} to 4.935V is the minimum voltage to find out most of the blind (short-circuit) pixels as in Fig. 12.

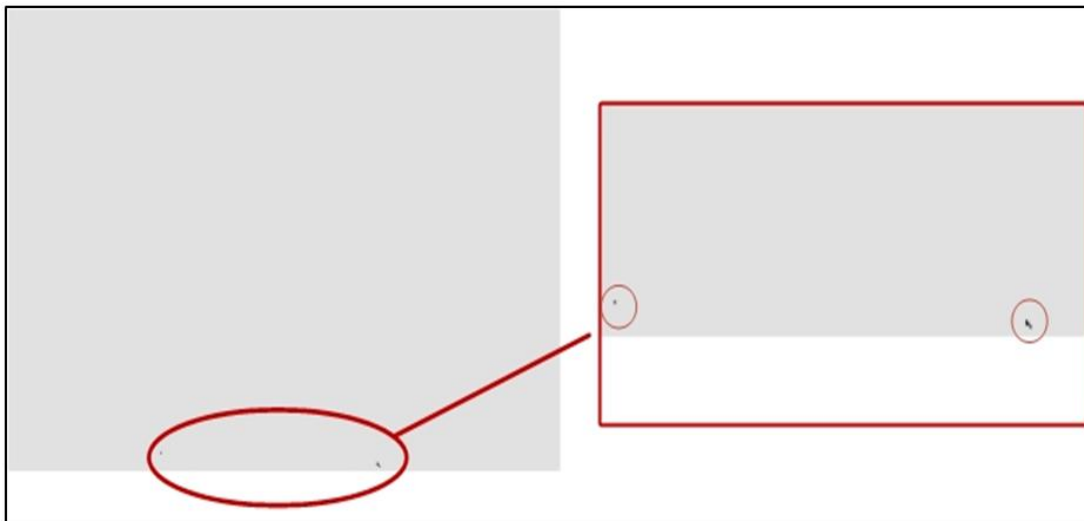

Fig. 12. IRFPA response image when V_{vsk} has decreased to 4.935V

Statistically, 3D demonstration by using Matlab exposes all type of the blind pixels which are easier now to take them off by a desired image processing filter like 3x3 median filter [16].

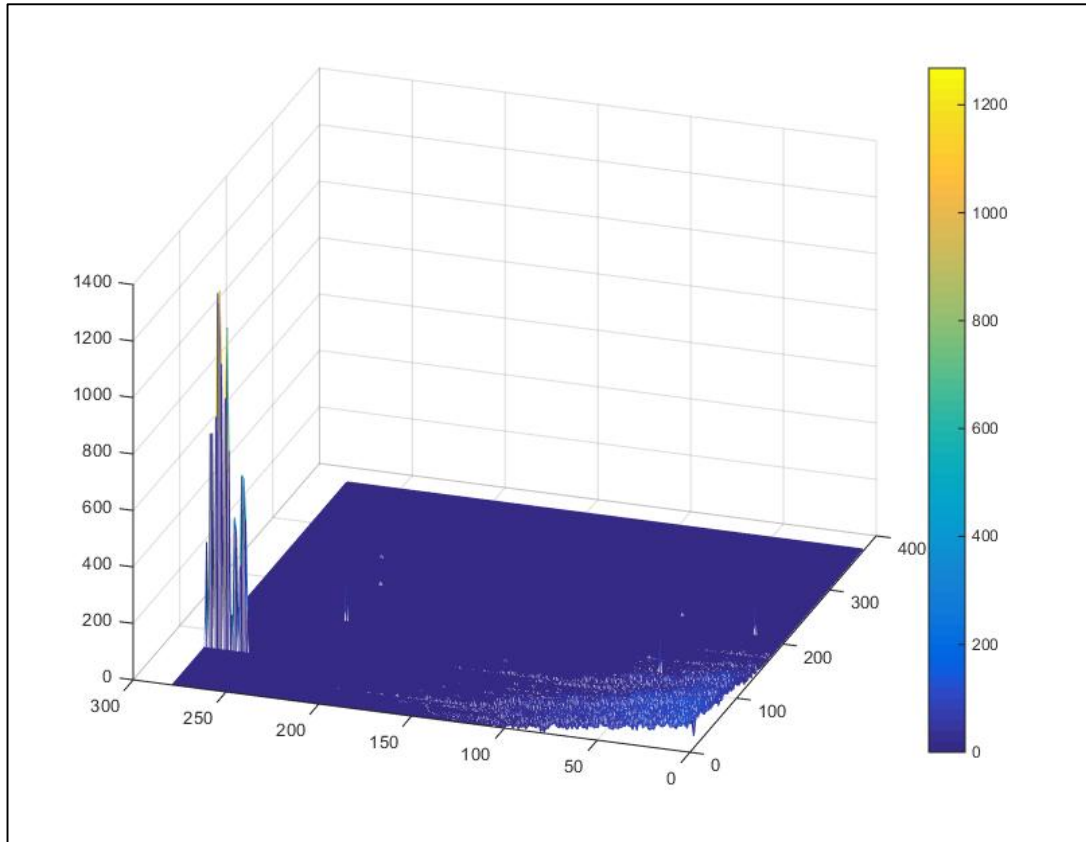

Fig. 13. Matlab mesh plot representation for IRFPA when V_{vsk} is 5.276V

Fig. 13 and Fig. 14 illustrates the IRFPA response image when V_{vsk} is 5.276V. Some blind pixels from the third type (bad pixels) has been exposed clearly. Fig. 15 and Fig. 16 illustrates the IRFPA response image when V_{vsk} is 4.935V.

Usually, image processing for detection, recognition, or identification passes through two major stages which are feature extractions and classification [17].

Fig. 17 illustrates the flowchart for the proposed technique that it has to extract the features, detect blind pixels through a classification algorithm, and update the blind pixels lookup-table. Due to the nature of blind pixels and from above results, Researchers recommend that any global-thresholding algorithm is enough for blind pixels classification [18]. This paper proposes using Otsu's method due to its simplicity for implementation and the nature of the problem in this study which does not require a complex classifier [19]. But, researchers apply special constrains on Otsu's method to make it sufficient for this proposed technique and to classify the pixels faster as follows:

- In case of an open-circuit pixel detection routine and when the V_{vsk} is maximum, Otsu's method has to use the mean value as a minimum value and find out the image maximum as usual.
- In case of a short-circuit pixel detection routine and when V_{vsk} is minimum, Otsu's method has to use the mean value as a maximum value and find out the image minimum as usual.

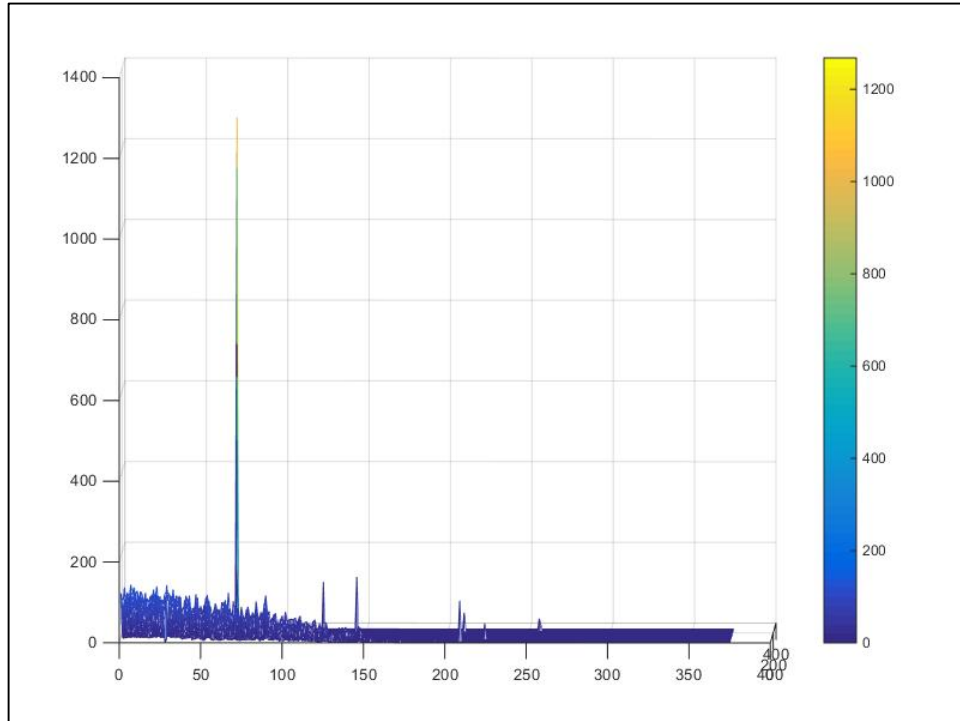

Fig. 14. Side view rotation for the 3D illustration for IRFPA image response when V_{vsk} is 5.276V

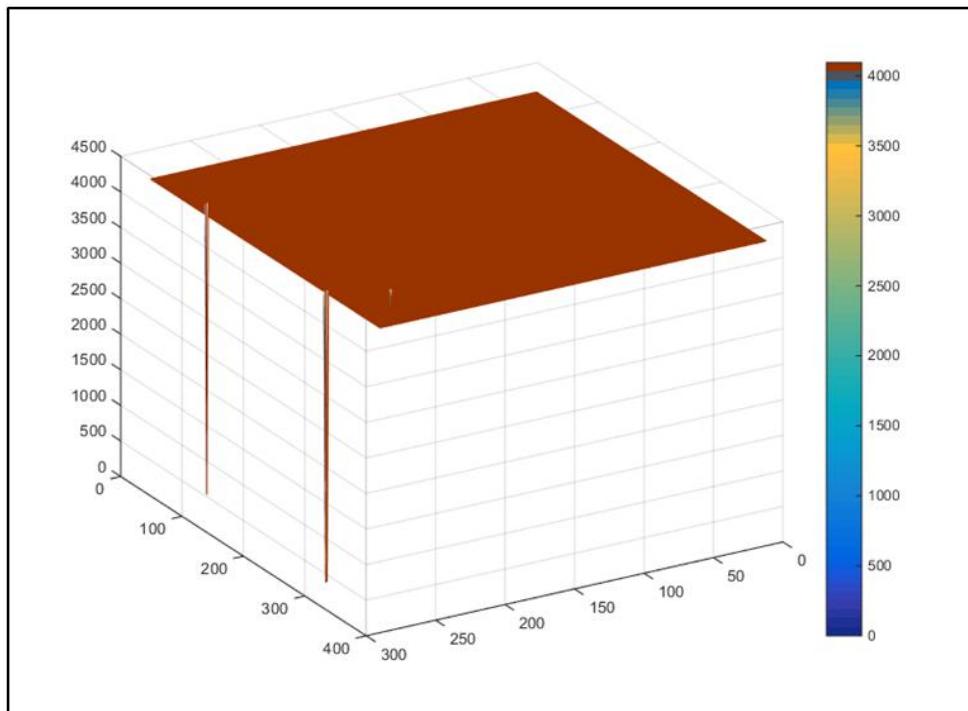

Fig. 15. Matlab mesh plot representation for IRFPA when V_{vsk} is 4.935V

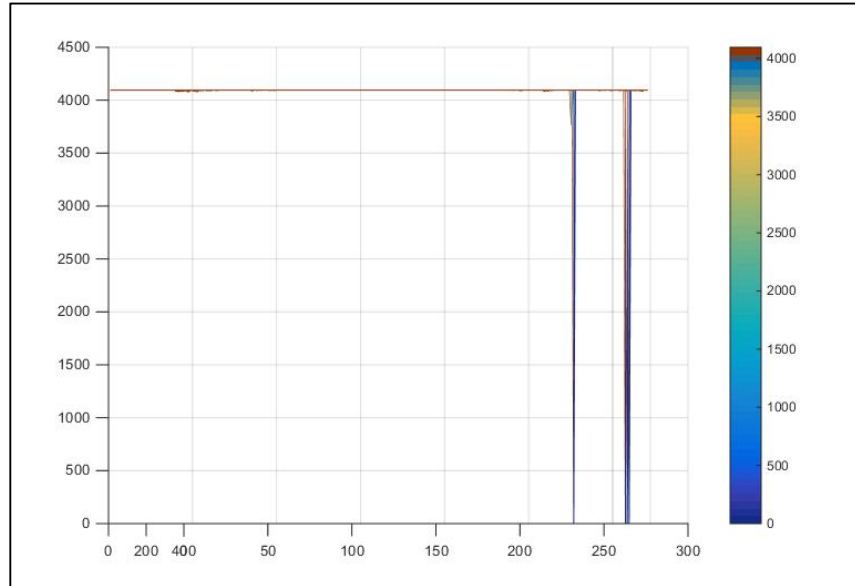

Fig. 16. Side view rotation of the 3D illustration for IRFPA image response when V_{vsk} is 4.935V

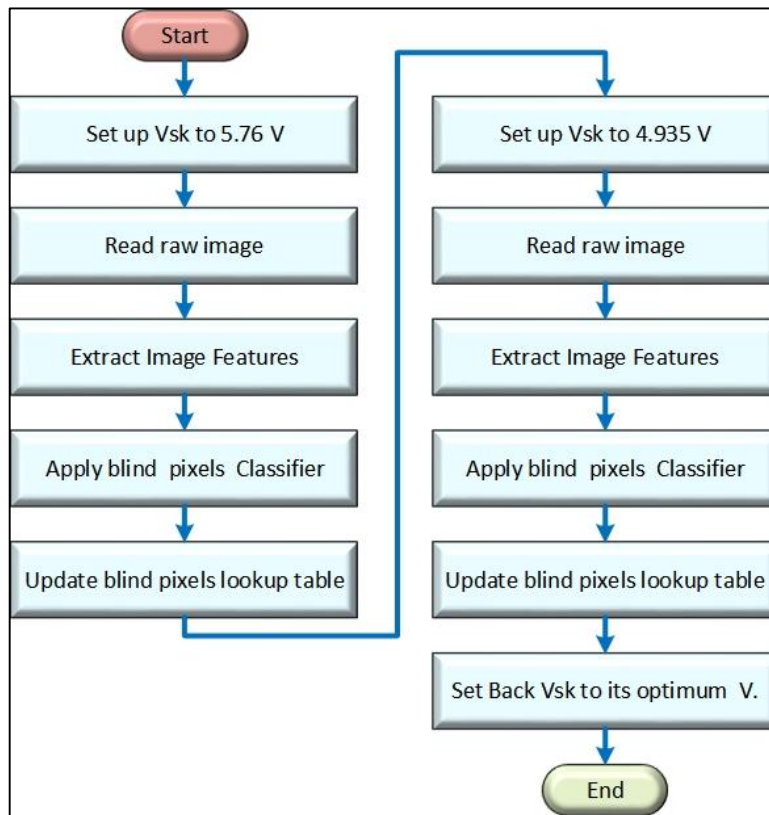

Fig. 17. Flow chart for the proposed technique

4 Results

Researchers acquired images after applying the desired technique for offline evaluation and did two tests to measure the success level of the proposed technique as follows:

1. (A minor test for assurance purpose). Researchers feed the acquired images to the same analyzing tool (Matlab software in our lab) that RBNUC process uses to detect blind pixels and compare them with results that have been found out by the proposed classifier. The experiment shows that the classifier and analyzing tool results are matched.
2. (A major test to qualify the technique). To compare the classified blind pixels by the proposed technique with the classified pixels that have been aggregated by an independent RBUNC process for the same IRFPA system, the results are in Table 1.

Table 1. Blind pixles estimation result

Technique	Blind pixels			Total
	Open-circuit pixels	Short-circuit pixels	Bad pixel	
RBNUC	19	9	45	73
Proposed technique	19	9	53	81

Table 1 illustrates that both techniques could detect the same blind pixels that (physically) have an internal electrical failure, exactly. But, the proposed technique exposed more bad pixels than RBNUC technique. The result makes sense because of images that acquired by referenced-based technique were from a certain region of interest e.g. researchers calibrated the IRFPA in range of temperature steps between 25°C to 55°C, but the proposed technique was experimenting the extreme voltage boundaries that IRFPA detector could reach without saturation.

5 Conclusion

This paper introduces a novel technique for blind pixels detection that offers great enhancement for SBNUC algorithms. The proposed technique is simple, fast to implement, and saves the memory and processor resources by applying straightforward rules during the system initialization stage. The proposed technique suggests a permanent hardware modification to excite V_{sk} through a programmable (variable) power supply and to control the V_{vsk} voltage automatically through the DSP or FPGA according to the core technology that is used in image processing card.

6 Future Work

To expand the research to study GFID in Fig. 8 and modify the processing card design by adding a programmable power supply like DAC8831 and connect it to the DSP.

Competing Interests

Authors have declared that no competing interests exist.

References

- [1] Scribner DA, Kruer MR, Killiany JM. Infrared focal plane array technology. Proceedings of the IEEE. 1991;79(1):66-85.
- [2] Beiser L. Unified optical scanning technology. USA: John Wiley & Sons. 2005;1-18.
- [3] Rodolfo R, Miguel F, Sergio NT, Jorge EP. Embedded nonuniformity correction in infrared focal plane arrays using the Constant Range algorithm. Infrared Physics & Technology. 2015;69:164-173.
- [4] Bae J, Ku B, Han DK, Ko H. Combining infrared and visible images using novel transform and statistical information. In Advanced Video and Signal-Based Surveillance (AVSS), Beijing; 2012.
- [5] Osia N, Bourlai T. A spectral independent approach for physiological and geometric based face recognition in the visible, middle-wave and long-wave infrared bands. Image and Vision Computing; 2014.
- [6] Algamdi A, Adas A. Novel technique for utilizing analogue video signal for IRFPA raw data transfer for calibration purposes. Journal of Advances in Mathematics and Computer Science; 2017.
- [7] Orzanowski T, Madura H. Test and evaluation of reference-based nonuniformity correction methods for microbolometer infrared detectors. Opto-Electronics Review. 2010;18.
- [8] Olbrycht R, Wiecek B, Swiatczak T. Shutterless method for gain nonuniformity correction of microbolometer detectors. In MIXDES-16th International Conference, Lodz; 2009.
- [9] Nguyen CT, Mould N, Regens JL. Dead pixel correction techniques for dual-band infrared imagery. Infrared Physics & Technology; 2015.
- [10] Hu J, Xu Z, Wan Q. Non-uniformity correction of infrared focal plane array in point target surveillance systems. Infrared Physics & Technology; 2014.
- [11] Yang W, Xie X, Chai Z. Human segmentation in infrared videos using Markov random field. In Green Computing and Communications (GreenCom), 2013 IEEE and Internet of Things (iThings/CPSCoM), IEEE International Conference on and IEEE Cyber, Physical and Social Computing, Beijing; 2013.
- [12] Nicolás C, Rodolfo R, Miguel F. FPGA-based neural network for nonuniformity correction on infrared focal plane arrays. Digital System Design (DSD), 2012 15th Euromicro Conference. 2012; 193-200.
- [13] Mou X, Cui Q, Zhang G. Background modeling for adaptive nonuniformity correction in IRFPA. In Optics Photonics and Energy Engineering (OPEE), Wuhan; 2010.
- [14] Fan F, Yong M, Jun H, Zhe L, Chengyin L. A combined temporal and spatial deghosting technique in scene based nonuniformity correction. Infrared Physics & Technology. 2015;71:408-415.

- [15] Woo DH, Kang SG, Lee HC. Novel current-mode background suppression for 2-D LWIR applications. IEEE Transactions on Circuits and Systems II, no. IEEE; 2005.
- [16] Wang Z, Zhang D. Progressive switching median filter for the removal of impulse noise from highly corrupted images. IEEE Transactions on Circuits and Systems II: Analog and Digital Signal Processing; 1999.
- [17] Daqrouq K, Sweidan H, Balamesh A, Ajour MN. Off-Line Handwritten Signature Recognition by Entropy; 2017.
- [18] Sezgin M, Sankur B. Survey over image thresholding techniques. Journal of Electronic Imaging; 2004.
- [19] Otsu N. A threshold selection method from gray-level histograms. IEEE Transactions on Systems, Man, and Cybernetics; 1979.

© 2017 Algamdi and Adas; This is an Open Access article distributed under the terms of the Creative Commons Attribution License (<http://creativecommons.org/licenses/by/4.0>), which permits unrestricted use, distribution, and reproduction in any medium, provided the original work is properly cited.

Peer-review history:

The peer review history for this paper can be accessed here (Please copy paste the total link in your browser address bar)

<http://sciencedomain.org/review-history/22195>