



Trotro Pass: Ghanaian Commercial Vehicle Passenger Accounting System

B. Kommey^{1*}, H. Maazu¹, A. S. Adjei¹ and J. Issah¹

¹Department of Computer Engineering, Kwame Nkrumah University of Science and Technology, Kumasi, 00233, Ghana.

Authors' contributions

This work was carried out in collaboration among all authors. Author BK came up with the idea, designed the study, the system architecture, system block diagram and system work flow, He also wrote the abstract, introduction, methodology and the conclusion of the manuscript. Author HM wrote the C code for the embedded system hardware and documented it for the manuscript. Author ASA designed and programmed the object oriented graphical user interface for the system and wrote the literature review. Author JI managed the hardware setup, software setup and well as evaluation and data analyses of the study. He also wrote the section "Test and Evaluation". All authors read and approved the final manuscript.

Article Information

DOI: 10.9734/AJRCOS/2019/v4i330117

Editor(s):

(1) Dr. Omidiora, Elijah Olusayo, Professor, Department of Computer Science and Engineering, Faculty of Engineering and Technology, Ladoko Akintola University of Technology (LAUTECH), Ogbomoso, Nigeria.

Reviewers:

(1) Lam Weng Siew, Universiti Tunku Abdul Rahman Kampar Campus, Malaysia.

(2) Raheel Muzzammel, The University of Lahore, Pakistan.

(3) Boyan Karapenev, Technical University of Gabrovo, Bulgaria.

Complete Peer review History: <http://www.sdiarticle4.com/review-history/53225>

Original Research Article

Received 15 October 2019

Accepted 17 December 2019

Published 24 December 2019

ABSTRACT

Commercial transport in Ghana is generally unsupervised; vehicle owners and transport managers alike lack tools to properly monitor and track the performance of drivers. Usually, fixed amounts are given to drivers as a daily goal, anything more than that is payment for the driver's services. This fixed amount is usually based on intuition and not on statistical data that at least estimates how much a driver makes in a day of commute. This project is intended to give commercial vehicle managers the ability to track location of vehicles and cumulatively estimate how much money is being made, up until end of a day of commute. This is achieved through a design that makes use of a distributed collection of embedded systems in the vehicle, equipped with GPS and cellular data connection, which would transmit and store information on a server. A user-friendly application would then query and display in real time the location of vehicles and estimate amount made so far

*Corresponding author: E-mail: bkommey.coe@knust.edu.gh;

up until end of the day. With feasibility and cost in mind some solutions are adopted and modified if need be. This coupled with embedded system design and software engineering, we develop a system that accomplishes the stated goals. An accuracy of 89.4% was achieved in our cumulative travel distance measurements.

Keywords: Minibus; monitor; accounting; occupancy; passenger; seat; transport.

1. INTRODUCTION

Ghana's public transport system has been dominated by private sector provision of paratransit for many years. It serves about 95% of public transport needs, often using shared taxis and minibuses ("trotro") [1]. The paratransit sector provides low service capacity; nevertheless, large number of vehicles is required to meet demand [2]. The dominance of these services means transport regulation is left in the hands of civilian car owners and managers alike. It is to that effect the Ghana Private Road Transport Union (GPRTU) has been created to regulate the cost of transport, nonetheless intuition and speculation is the only means by which rates are discerned for shorter or intermediate distances that have not been specified. A passenger would be concerned about how fair the fare is. A vehicle operator would be concerned about reaching the target amount set by the manager. The manager or "car owner" would be concerned about how much the vehicle operator is making, that is whether the target amount has been reached or not. There are instances where the owner works for himself but the advantages of a system such as what we have suggested may still be relevant to an owner who values self-accountability. As elucidated in the problem statement above, the position of a car owner in the grand cooperation of owner, driver and passenger is often one of passivity and patient expectance. Though he/she is the main purveyor of the service, the owner is relegated to a position in which the driver ultimately decides the profits that they receive. Our paper aims to do away with this illogical conclusion using innovative and efficient technological techniques that might allow owners oversight over the daily activities of their employees and an estimate of the earnings that they could expect at the end of the day based on verifiable data and not only on the word of the driver.

2. RELATED WORK

2.1 Passenger Flow

There have been many attempts at passenger counting with varying degrees of success. But,

an interesting benefit to dealing with vehicle occupancy is the fact that more pervasive methods of counting can be used. Commercial vehicles normally have fixed routes confined within two main locations ("last stops"). Between these two locations are intermittent stops where passengers may enter or exit. In order to accurately determine the number of passengers in a vehicle for a trip from any of these intermittent stops to another, it is at least required that we keep track of the total number of passengers alighting and boarding. To this effect, Antons Patlins and Nadezha Kunicina [3] proposed a system of passenger counting using "such an estimative scientific method of remote sensing as photogrammetry." In this proposed system, the dynamic movement of passengers to and from the vehicle is analyzed. The inflow and outflow of passengers is modelled as in Fig. 1.

The equation for the sum of passengers between two stops is presented below;

$$S_n = S_{n-1} + In_n - Out_n \quad (1)$$

2.2 Seat Occupancy

Attempts at sensing the presence of vehicle occupants using pressure sensors [4,5], occupant classification using stereovision [6] and optical sensors [7,8] have been reported. These methods, optical and weight-based have been proven unsuitable for dynamic observations whereas capacitive sensors have proven useful and advantageous [9]. Fig. 2 presents a simplified model of the capacitive sensor setup and its capacitance to the vehicle chassis, which serves as ground. It is obvious from this model that a human, made of 72% water [10], sitting on the seat would change the dielectric makeup of capacitance C2 between sensor "S1" and vehicle's roof "GND", increasing the amount of time it takes capacitance C2 to charge and discharge.

This configuration is approximated as a parallel plate capacitor model assuming the charge density on the plates are uniformly distributed and that the only capacitance exists between the sensor and the chassis as indicated [11]. Below is a simplified equivalent circuit diagram,

including the stimulus and respond pins, V_S and V_R respectively.

The capacitance of two plates in parallel is given by;

$$C = \frac{\epsilon_o \epsilon_r A}{d} \quad (2)$$

Where;

“A” = plate area in meter squared

“d” = distance between plates in meters

ϵ_o = permittivity of free space = 8.85×10^{-12} F/m

ϵ_r = relative permittivity of the dielectric substrate between the plates.

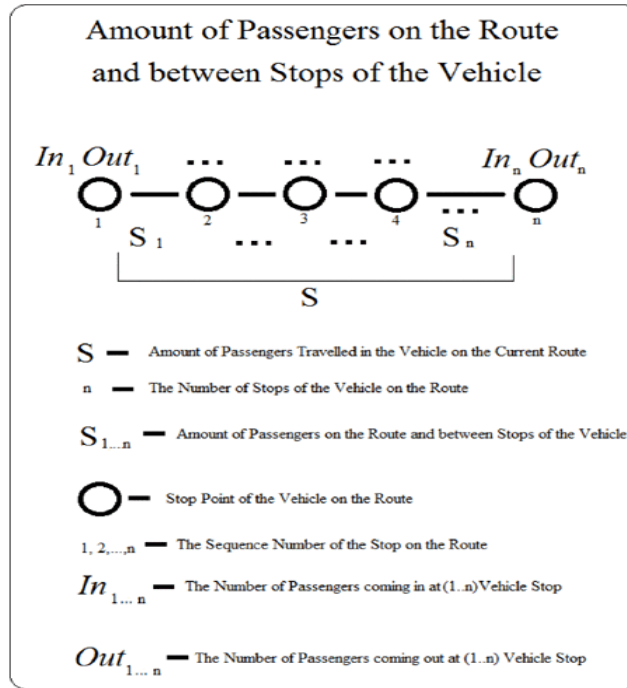

Fig. 1. Passengers on route between stops [1]

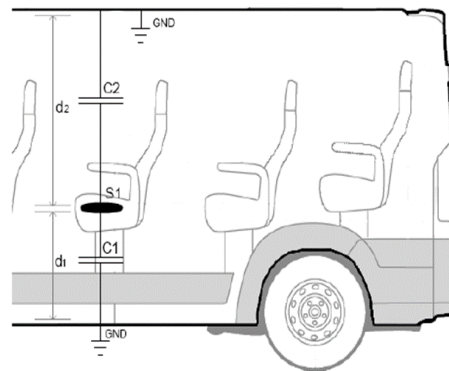

Fig. 2. Model of the capacitance between sensor plate and chassis [11]

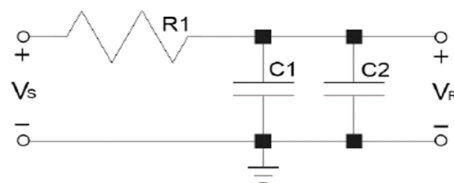

Fig. 3. Circuit representation of the capacitive seat sensor [11]

A, d and ϵ_o are constant thus only ϵ_r can change the capacitance. One thing to note is the fact that parallel plate capacitance has electric fields that are not only limited to sensors but can bend outwards, and is a phenomenon called fringing. This is corrected by increasing A by 13% to account for its effects [12]. An effective dielectric constant (ϵ_e) is derived by approximating the capacitive sensor as a microstrip transmission line which consist of a conductive strip of width 'W' (sensor diameter) and a wider ground plane (vehicle's chassis), separated by a dielectric substrate of thickness 'H' (area between electrode and ground). The effective dielectric constant (ϵ_e) is less than the substrate's dielectric constant since a part consists of air and can be approximated as follows [13]:

When $\left(\frac{W}{H}\right) < 1$:

$$\epsilon_e = \frac{\epsilon_r + 1}{2} + \frac{\epsilon_r - 1}{2} \left[\left(1 + 12 \left(\frac{H}{W} \right)^{-1} \right)^{-1/2} + 0.04 \left(1 - \left(\frac{W}{H} \right)^2 \right) \right] \quad (3)$$

When $\left(\frac{W}{H}\right) \geq 1$:

$$\epsilon_e = \frac{\epsilon_r + 1}{2} + \frac{\epsilon_r - 1}{2} \left(1 + 12 \left(\frac{H}{W} \right)^{-1} \right)^{-1/2} \quad (4)$$

The time constant τ on C_{total}

$$C_{total} = C_1 + C_2 \quad (5)$$

$$C_{total} = \epsilon_o A \left(\frac{d_1 \epsilon_{e2} + d_2 \epsilon_{e2}}{d_1 d_2} \right) \quad (6)$$

Where ϵ_{e2} varies depending on whether a human who is made up of 70.4% water [10] is occupying a seat or not.

3. MATERIALS AND METHODS

3.1 Troto Pass System Architecture

The system architecture is best described in Fig. 4. The vehicle's seats are fitted with aluminum foil plates which form the capacitive sensing plate. The master Seat Occupancy Detection Unit (SODU) collects all relevant seat information from "slave" SODUs and transmits the data via the internet to the backend server which then processes the information and makes it available for viewing on a mobile device.

3.2 Seat Occupancy Sensing

With the help of the flow chart in Fig. 5. We recap the sensing technique presented by [11] with some modifications. The stimulus pin is simply set to a logical high and a response is awaited. Once the response pin is high, the stimulus pin is set to low and a response is awaited. Once response pin is low, the timer is stopped and its value recorded. This is repeated several times. This repetition is done to counteract a problem initially faced which was due to the sporadic changes in recorded values. The improved sensing technique (Fig. 6) averages the recorded values. A 'seat mask' which is simply a sequence of bits representing each seat (i.e. a '1' a bit position of the 'seat mask' means seat one is occupied.)

With a time constant;

$$\tau = RC \quad (7)$$

It is well documented that by doubling the capacitance in a simple RC circuit like the one shown in Fig. 3, the time constant is also doubled. Since we are dealing with a moving car it is to our advantage that the time constant be kept small enough to accelerate the sensing process and large enough to be discernible by an otherwise slow and inexpensive embedded microcontroller. Assuming that a time constant of RC is desired, given a timer/counter count register B bits wide, it is noted that the required frequency for the counter to overflow in $2 \times 5\tau$ seconds (i.e. capacitor charges up to a logical high and down to a logical low per the algorithm presented above) is given by the equation below.

$$F = \frac{2^B - 110\tau}{10\tau} \quad (8)$$

This would hold for an ideal case, but unfortunately have overheads when invoking and returning from functions and interrupt services. These delays are considered when programming the microcontroller.

3.3 The Seat Occupancy Detection Unit (SODU)

Key components suggested by our trotoPass system architecture include

- Microcontroller
- GPS Module
- GSM Module
- Zigbee Module

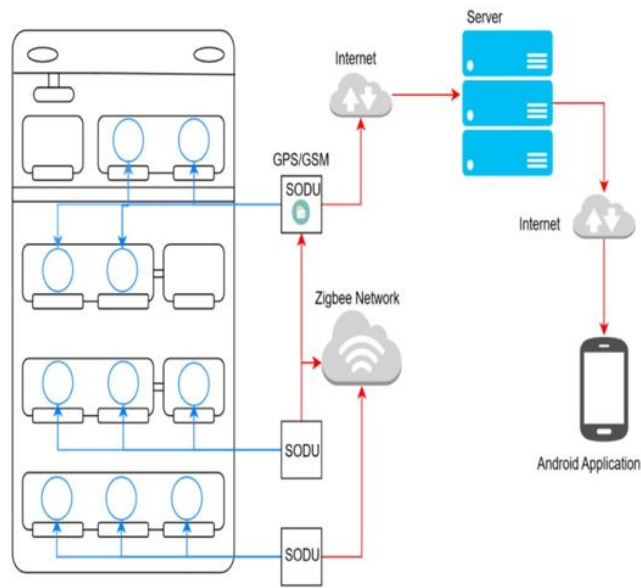

Fig. 4. Troto pass system architecture

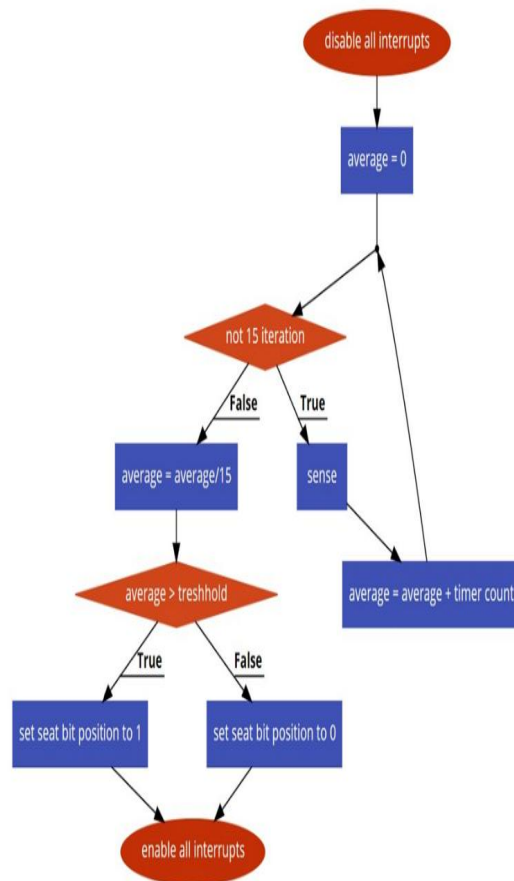

Fig. 5. Seat occupancy sensing algorithm

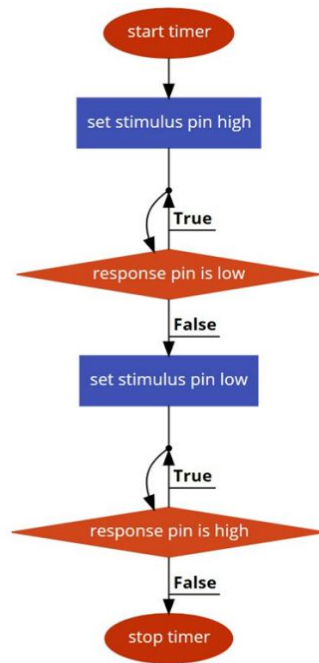

Fig. 6. Trotro pass improved sensing algorithm

The complete system is to be powered via the in-vehicle cigarette plug outlet which has a typical maximum rating of 12V and 3A. Due to the limited availability and cost of obtaining certain evaluation and breakout boards our prototype design is limited to that of one “master” SODU.

3.4 Microcontroller

Inexpensive microcontrollers such as those from the Atmel Attiny line of microcontrollers should suffice for the passenger accounting system but for this implementation, the Atxmega256A3BU (Evaluation Board) microcontroller is employed. The key features of this microcontroller are listed below;

- USART for simultaneous GPS, GSM and ZigBee communication.
- It also has 47 programmable I/O pins, more than needed for.
- It also has 7 16-bit Timer/Counters of which just one is needed for timing the RC circuit formed by the sensor setup.

Using the Evaluation board as a template, all unnecessary components to the design are stripped away. A discussion of the proposed microcontroller schematic is presented in Fig. 8. The microcontroller operates on 3.3V voltage

supply thus the need for a voltage regulator. In this case, an NCP1117LSP as shown in Fig. 7.

A Low-dropout regulator is used, which is capable handling input voltage of up to 18V while giving an output of 3.3V. Pad “PS” is connected to the positive terminal of the vehicle cigarette plug and pad GND is connected to its negative terminal.

In Fig. 8, the schematic of the microcontroller is presented along with the light indicators for determining the state of the embedded software. LED1 serves the purpose of indicating if all driver initializations have been completed. LED2 is planned as a toggling indicator of microcontroller activity.

On the right of the microcontroller is the USB mini, A connector for reprogramming the microcontroller, will persist beyond production phase in case updates to software is needed. The flash mode is triggered using push button “S1”.

Below the microcontroller are the decoupling (LDO regulator to microcontroller) capacitors. A VCC to AVCC connection is made through an inductor to power analog circuitry within the microcontroller.

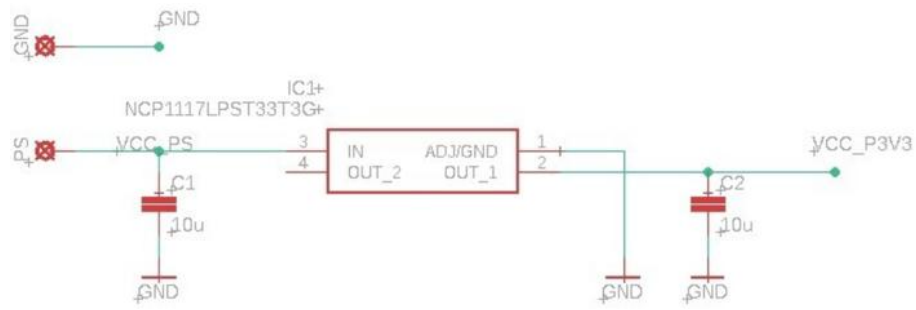

Fig. 7. MCU power supply

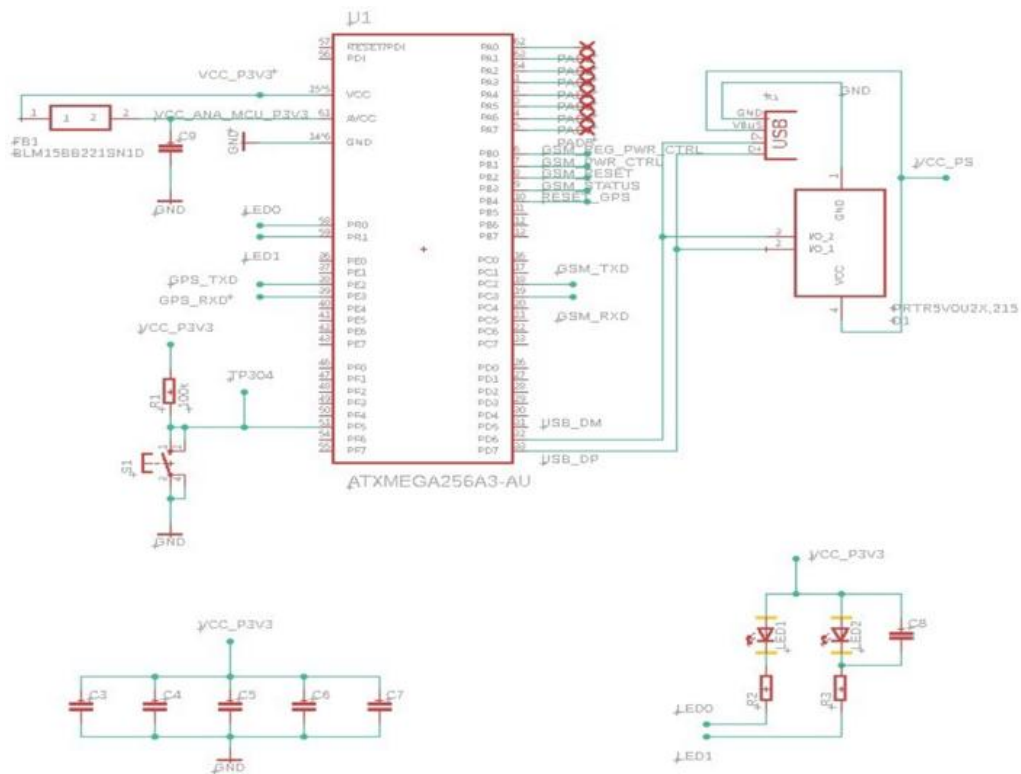

Fig. 8. Trotro pass MCU schematic

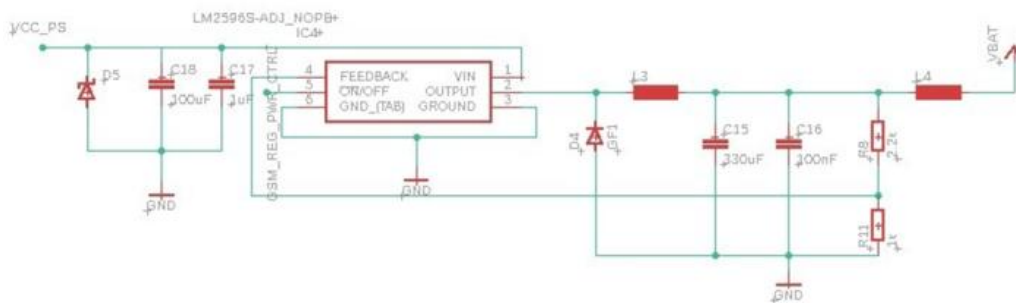

Fig. 9. GSM power supply

3.5 GSM Module

It is preferable to implement the system with a 3G module, but due to cost and accessibility we default to the more common sim900 GPRS enabled module. Since the board is to be powered by a DC to DC converter (automotive), it is advised that our efforts be guided towards achieving a noise suppressive design in order to decrease the risk of degradation of the RF performance of the sim900 due to switching noise. The recommended design per sim900 user manual is depicted in Fig. 9.

4. RESULTS AND DISCUSSION

4.1 Seat Occupancy Testing

Testing was split into two stages. First, seat occupancy sensing with a setup depicted in Fig. 10. With an array of resistors fixed in a breadboard a resistance within the range of $1M\Omega$ to $20M\Omega$ is chosen to be connected between the stimulus and response pins; this helps in regulating the sensitivity and time required for charge. The laptop powering the microcontroller is kept plugged in. This makes the reference ground the building itself. The Timer/Counter clock is then set to a frequency of 2MHz, after which, the CNT register is sample at every sensing iteration. With $4M\Omega$ of resistance selected, it is discovered that with no human occupant, the CNT register had a value averaging about 33. Upon occupying the seat, counts as high as 330 were observed while averaging in the range 100 to 300. The threshold count is then set to 100 and six different individuals test the occupancy by sitting on the seat. Our system recognized all occupants.

4.2 Trip Distance Test

In the second stage of testing, seat occupancy is simulated using 4 capacitors (two per seat) while tracking the distance travelled and amount paid via an android application. Applying the same sensing algorithm, a threshold was set for when two capacitors were connected as opposed to one, thus, interpreting two connected capacitors as an occupied seat as opposed to one capacitor (i.e. empty seat).

At the instance this screenshot was taking, the app was reporting a cumulative trip distance of 170m, an amount made of GHS0.389 (rate of GHS0.8 per 350 m) and 2 seats occupied (i.e. all 4 capacitors were connected).



Fig. 10. Trotro pass sensor setup testing

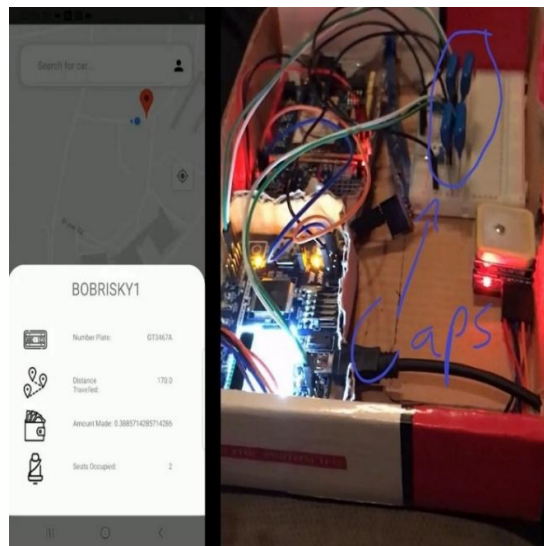

Fig. 11. Trotro pass trip distance testing

4.3 Evaluation

Fig. 12 depicts the planned trips for trip distance testing. The plan was to move the vehicle in 4 trips;

1. Trip 1: activate one seat and move 160 m
2. Trip 2: activate two seats and move 220 m
3. Trip 3: deactivate all seats and move 210 m
4. Trip 4: activate one seat and move 300 m

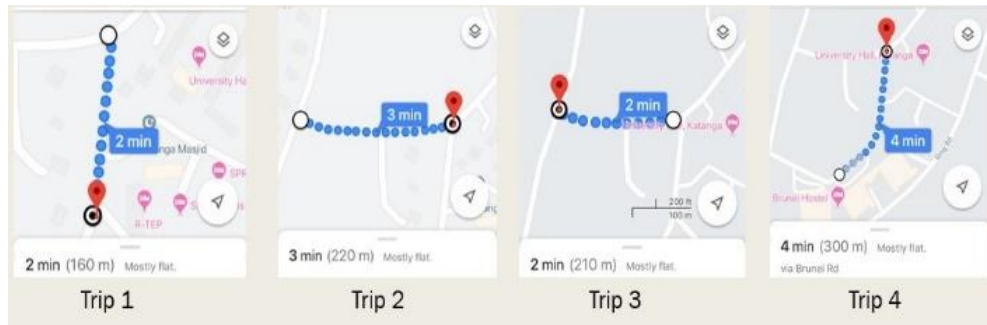

Fig. 12. Trotro pass planned trips

Table 1. Summary of expected and reported trip distance

Trips	Google distance	Seat mask	Seats occupied	Trip distance	Application Report
Trip 1	160 m	00000001	1	160*1= 160 m	
Trip 2	220 m	00000011	2	220*2=440 m	
Trip 3	210 m	00000000	0	210*0=0 m	
Trip 4	300 m	00000010	1	300*1=300 m	
				900 m	805 m

Table 1 summarizes the planned trips. A total distance of 805 m was reported (i.e. 89.44% of the expected 900 m of the total trip distances).

5. CONCLUSION

The feasibility of such a passenger accounting system using seat occupancy was proven. With regards to our objectives, we have been able to record and keep track of the vehicles location and total trip distance for every occupied seat connected to the system. Our app can dynamically listen for changes to the vehicles state in the database while presenting to the vehicle owners the location of vehicles and cumulative estimate of the amount of money made (89.44% accuracy). A major challenge was the delay in transmission. This problem may be attributed to the slow 2G network provided by the GSM module. Modules with 3G or better network support are highly recommended. Delays in transmission could also be improved with unreliable transmission protocols since the generation as many “snapshots” of the vehicle as possible is of greater concern to us. Perhaps non-volatile memories could be used for storing data that may have been lost due to the lack of cellular network coverage, for retransmission.

COMPETING INTERESTS

Authors have declared that no competing interests exist.

REFERENCES

- Fouracre PR, Kwakye EA, Okyere JN, Silcock D. Public transport in Ghanaian Cities - A Case of Union Power. *Transport Reviews*. 1994;14(1):45-61.
- Yobo E. The politics of public transportation in Ghana: The Case of Metro Mass Transit Limited; 2013. [Online]. Available:<http://ugspace.ug.edu.gh/handle/123456789/5284>. [Accessed 8 12 2018]
- Patlins A, Kunicina N. The new approach for passenger counting in public transport system, in *IEEE*, Warsaw, Poland; 2015.
- Kasten K, Stratmann A, Munz M, Dirscherl K, Lamers S. iBoltTechnology— A weight sensing system for advanced passenger safety. *Advanced Microsystems for Automotive Applications*. 2006;171–186.
- Gagnon SD, Husby HS. Seat occupant sensing system. *United States of America Patent 5 971 432*; 1999.
- M. D. a. A. M.-H. A. Giralt. Detection and classification of passenger seat occupancy using stereovision. *Proc.IEEEIntell. Vehicles Symp*. 2000;714–719.
- Stefan W, Otto L, Becker G, Castillo-Franco M, Mirbach B. A cascade detector approach applied to vehicle occupant monitoring with anomni-directionalcamera.

- Proc. IEEEIntell. Vehicles Symp. 2004; 345–350.
8. Fritzsche M, Prestele C. Vehicle occupancy monitoring with optical range-sensors. Proc. IEEE Intell. Vehicles Symp. 2004;90–94.
 9. George B, Zangl H, Bretterkieber T, Brasseur G. Seat occupancy detection based on capacitive sensing. Instrumentation and Measurement. 2009;58(5):1487–1494.
 10. Watson P, Watson I, Batt R. Total body water volumes for adult males and females estimated from simple anthropometric measurements. The American Journal of Clinical Nutrition. 1980;33(1):27–39.
 11. Zeeman AS, Booyesen MJ. Capacitive seat sensors for multiple occupancy detection using a low-cost setup. Stellenbosch; 2013.
 12. Hoch E. Electrode effects in the measurement of power factor and dielectric constant of sheet insulating materials. Bell System Technical Journal. 1926;5:555.
 13. Bahl I, Trivedi D. A designer's guide to microstrip line. Microwaves. 1977;16(5): 174-175.

© 2019 Kommey et al.; This is an Open Access article distributed under the terms of the Creative Commons Attribution License (<http://creativecommons.org/licenses/by/4.0>), which permits unrestricted use, distribution, and reproduction in any medium, provided the original work is properly cited.

Peer-review history:
The peer review history for this paper can be accessed here:
<http://www.sdiarticle4.com/review-history/53225>